



ENGINEERED *Excellence*™



HMI & Digital Screen Products



Designed and
Manufactured
in the USA



Engine Monitoring and Alert Communications System.

When an engine is malfunctioning the ECU transmits the area of the malfunction as a fault code.

The fault code is often used to turn on a lamp or an alert indicator. The EntelNet™ system records these fault codes and sends the data to the technician giving them a heads up of possible problems or a means to diagnose the engine's health remotely.



Get the technicians involved.

- No additional costs
- Send the engine and other critical data anywhere in the world to be diagnosed.
- Helps reduce warranty costs and can help lessen repair time.
- Data can be viewed on a secure website for remote systems diagnostics.

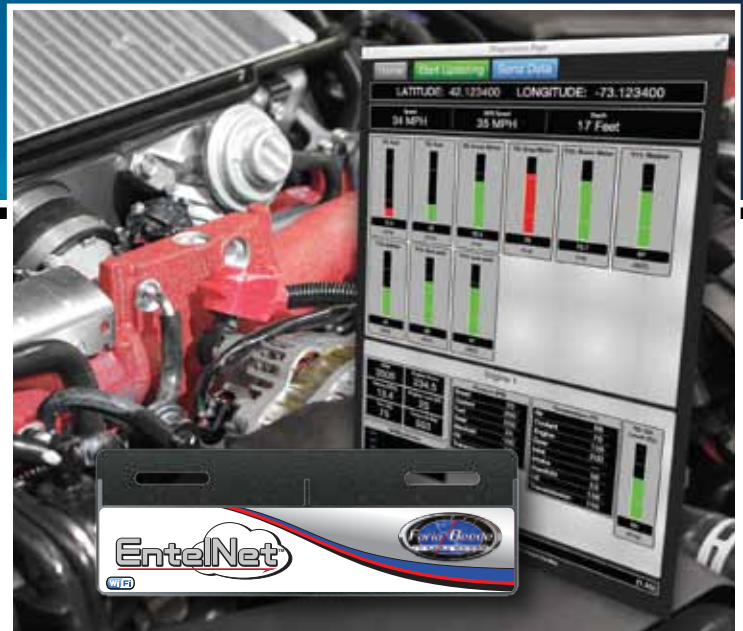

Connected directly to the CAN Bus, Real-Time data is sent by the EntelNet™ wireless module (Wi-Fi™).

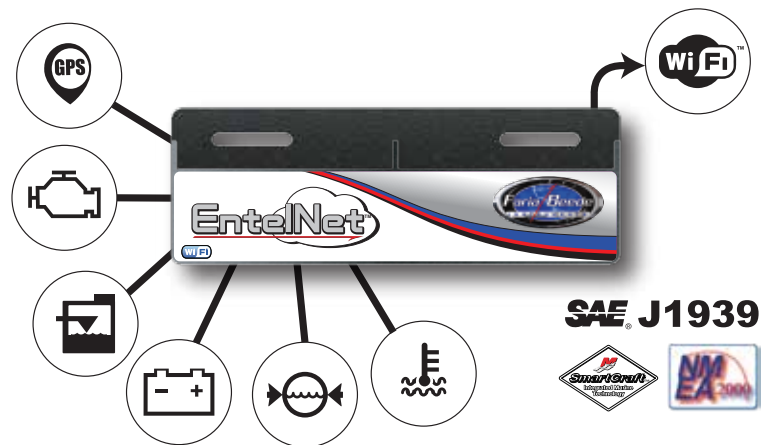

The data (GPS speed, Map position, Instrument data and CAN error codes) is displayed in an easy to read website and can be viewed by any internet capable device i.e. Smart Phone, Tablet or Computer.

The engine information can then be sent to a repair facility, via e-mail, giving your repair technician a heads up that you're having problems.



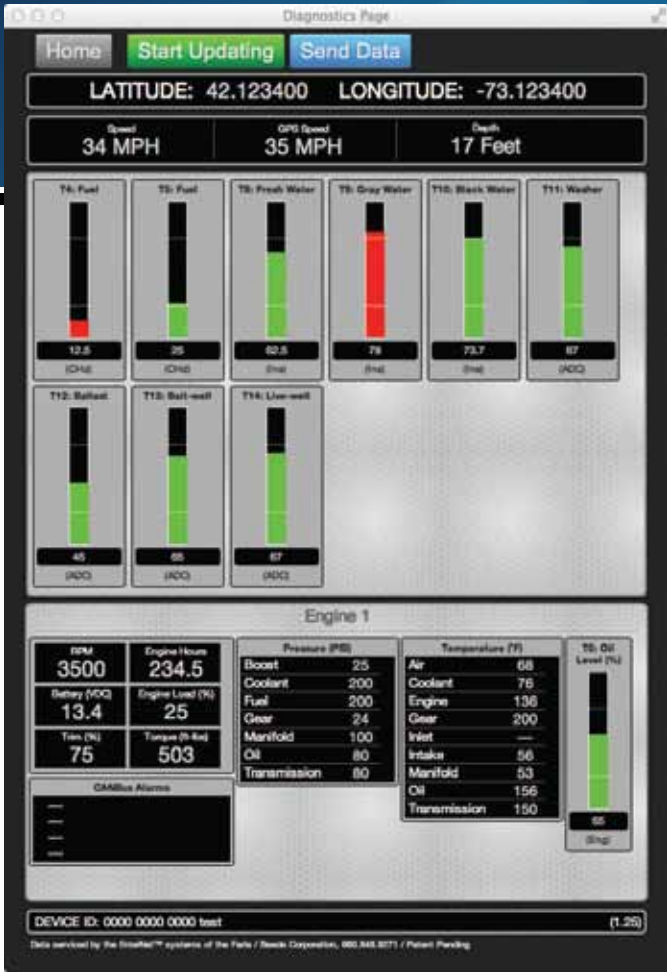

Local HTML Report Website

Use the EntelNet™ and your internet capable device to monitor CAN data being sent by the engine ECU and other critical vessel information right from the palm of your hand.



The EntelNet™ service is a multi part system which combines the information received from the engine ECU (via CAN Bus), Analog (resistance, voltage, etc.) or Serial data (RS-232 for NMEA 0183, typical for GPS) and an over the air communications system, i.e. Wi-Fi, to provide remote control and monitoring of on-board systems.

Send your engine data to the cloud.

When in range of a registered Wi-Fi hot spot, the EntelNet™ can automatically send the engine and environmental data directly to a 24 hour, 7 day a week monitoring server.

Technicians are notified of any faults logged by the EntelNet™. The server aids the technician with logged history of the vessel, providing a clearer picture of the conditions which may contribute to the fault and help provide a faster response.

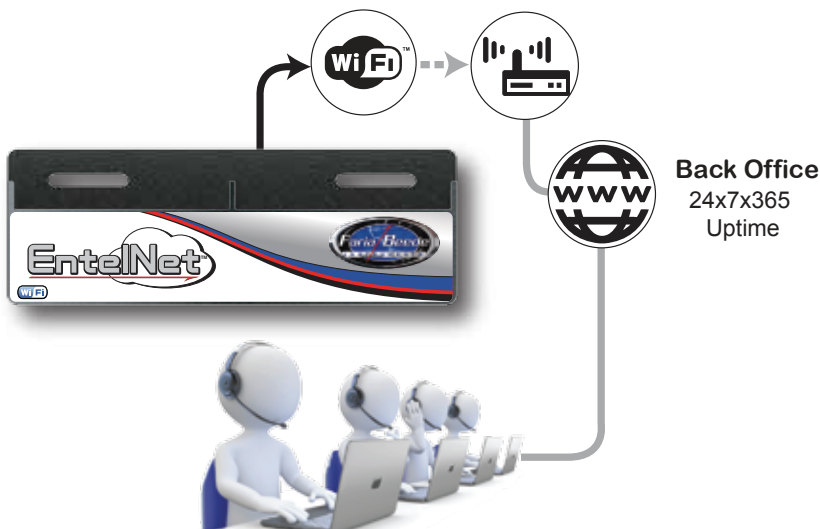

The screenshot shows a web interface titled 'Engine Monitoring' with a table of data. The table has multiple columns, including time, RPM, and other engine parameters, with rows of data entries.

Data can be viewed on a secure website for remote systems monitoring and diagnostics.



A complete solution for remote instrument monitoring!

Wi-Fi Module only

SD0062

Faria Bus

- Requires MG3000



SD0066

Direct to J1939 CAN Bus



SD0065

Direct to NMEA CAN Bus



Custom OEM solutions available.

Wired to the CAN Bus with USB charging

SD0068

- NMEA & J1939 inputs
- up to 5 Analog inputs
- Digital switched outputs
- USB charging station

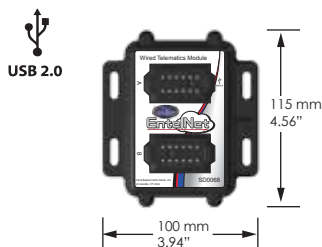

Android Application

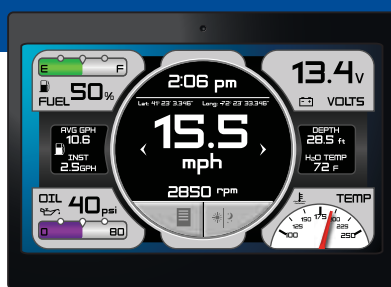

- Standard and Secondary instruments
- Tank monitoring and control
- Fuel Management
- Error Codes

Built from the ground up to be a touch-based user interface. The application is built directly on the Android operating system. Each screen is optimized to maximize the touch screen. Large target areas ensure smooth operations even in the harshest environments.

Custom Designed Application

Real-Time system data sent from the engine ECU and Analog inputs is displayed in the dedicated Android app. The system data, GPS speed, Map position, Instrument data, Asset monitoring data and CAN error codes are displayed in a highly customizable, virtual instrument dash board.

Multiple "pages" can be displayed including:

- Standard and Secondary instruments
- Ballast Tank monitoring and control
- Fuel Management
- Error Codes



Built to be touched

Ruggedized Tablets

These tablets are waterproof, dust-tight and ruggedized to handle harsh environments. The perfect companion for the EntelNet system for digital engine monitoring and glass dashboard applications.

Combined with our dedicated app for Android your engine data is right in the palm of your hand.

SONY

32 bits Qualcomm Snapdragon 801 Quad-core
3 GB DDR3 RAM
16 GB Flash memory for Data

IPS with Triluminos™ and X-Reality™ for Mobile

Housing - Water Resistant, Dust Proof
USB (MHL 3.0), microSD (up to 128GB),
microSDHC, headset jack (DNC 5 pin), magnetic
connector

Weight: 10" - 426 kg (1 lb) 8" - 270 kg (.6 lb)

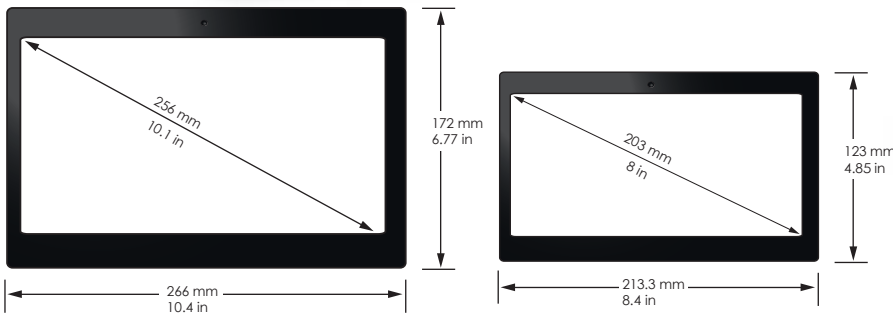

RTC-900R

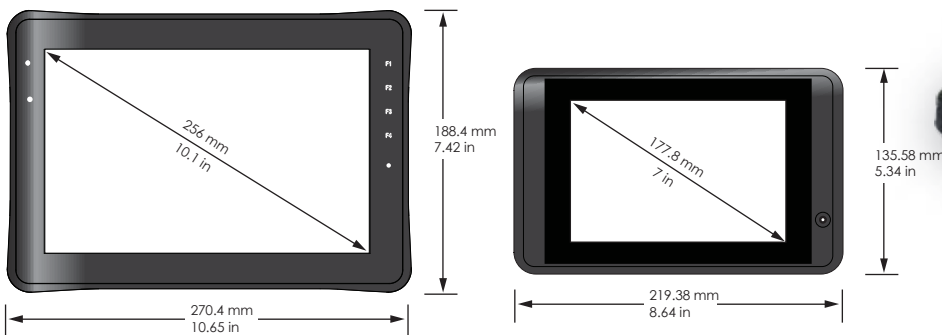

MEON® an ASUS assoc. co.

NVIDIA® TEGRAM 2 1.0 GHz Dual Core
Processor

1GB DDR2 RAM

10.1" WXGA (1280 x 800) TFT LCD Display

7" WXGA (1280 x 800) TFT LCD Display with
Sunlight readable option.

Rugged, Water and Dust Proof, IP65 Compliance

Micro SD Card Slot, 5M Pixel Rear Camera, 1.2M
Pixel Front Camera

WiFi 802.11 b/g/n , Bluetooth® 2.1 + EDR

Weight: 10" - 1.1 Kg (2.4 lb) 7" - .57 kg (1.2 lb)



RTC-700A

The “Mach” products are multi-functional / multi-purpose display centers for the commercial, industrial, recreational, military and marine markets. The MACH-7 (available with a 7.0” LCD screen) is based on the Android operating system for maximized flexibility and is easily installed along with other instruments and control switches.

Engine and Generator; monitoring, diagnostics, parameter monitoring, Navigation, Charting and Entertainment are major features designed into the “Mach” series architecture.

The distinguishing features of the product are a highly customized and feature rich graphical user interface, touch screen, Bluetooth and Wireless or Wired remote keypads providing a rich environment to meet future expansion needs, including telematics and the ability for remote monitoring and control of assets.

DISPLAY	7" WVGA, 800 x 480, 16 bit color depth, 550 cd/m ² (Minimum)
INTERFACES	
- CAN	CAN Spec 2.0B Protocols include J1939, NMEA 2000 and SmartCraft
- SERIAL	Faria Bus, RS-485, RS-232
USB	1 x USB 2.0 in Deutsch connector
VIDEO IN	Analog Video in, NTSC or PAL
- AUDIO	Stereo input and Stereo output
BLUETOOTH	Built-in 2.1 (Optional)
- INPUTS	9 x in (8) Software configurable: Analog: 0-5V (1) Software configurable: Digital Pulsed input
- OUTPUTS	(3) Software configurable: Digital
- GPS	NMEA 0183 in Deutsch connector or built in (Optional)
- WLAN	Built-in 801.11 b/g
- GSM/GPRS	Built in (Optional)

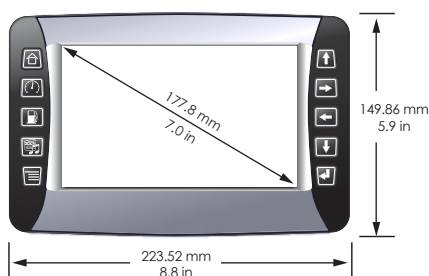

32 bits ARM processor, with 1 GB DDR3 RAM (Scalable)
2 GB NAND Flash memory for Data (Scalable)
microSD Memory Flash (built in)

TFT direct sunlight readable, touch screen display with anti-reflective coating.
LED back-lighted display

Housing - Plastic
10 application controlled soft-buttons
Buzzer - for sound notifications



Made for Android™



Environmental Specifications

- IP67 ingress protection
- Voltage: 12 or 24 V
9 - 32 VDC operating range



Is size an issue?

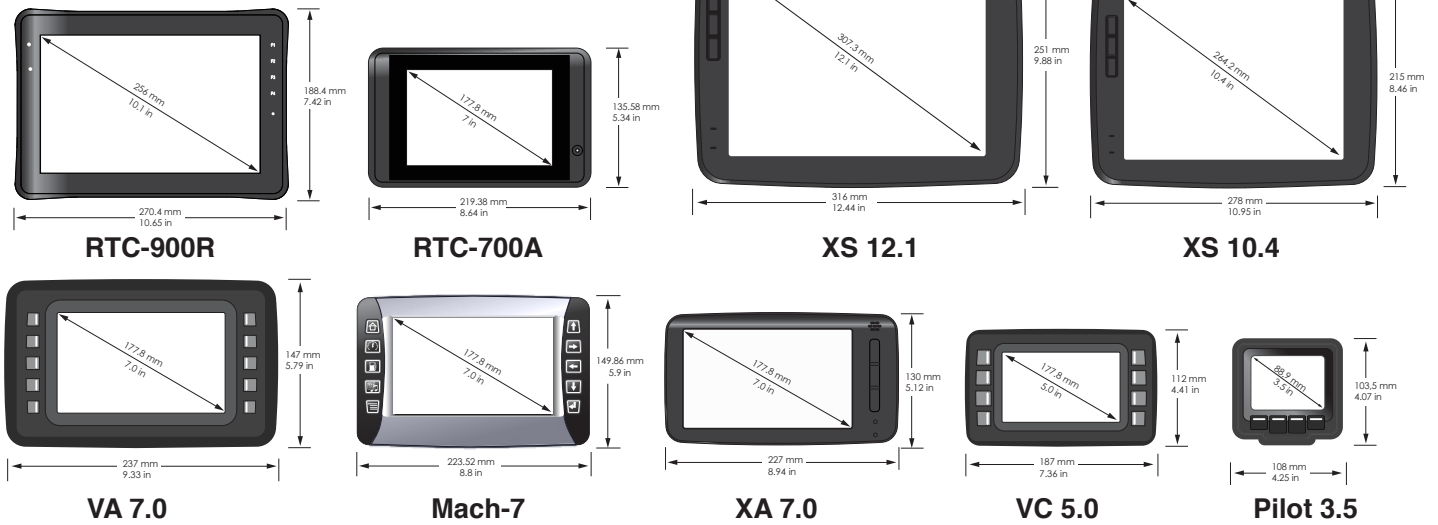

We've got the screen product to fit your needs.

Full color instrumentation display

Pilot VI 3.5

Pilot VI is an easily configurable, full-color 3 1/2" display enabling appealing user interfaces in a compact form factor.

Designed especially for the off-highway and industrial markets, Pilot VI offers exceptional readability and all-weather performance. It is suitable for both bracket mounting and integration in a dashboard. With the **QuiC™** software configuration tool you can rapidly program the Pilot VI without having specific software skills.

DISPLAY	3.5" QVGA, 320 x 240, 24 bit color depth, 400 cd/m ² (Minimum) TFT with LED backlight
INTERFACES	
- CAN	2 x CAN Spec 2.0B Protocols include J1939 and CAN open
USB	1 x USB 2.0 in Deutsch connector
- AUDIO	Buzzer for sound notification
- OUTPUTS	(2) High-current, 1.25A, high-side switched outputs
POWER SUPPLY	12 or 24 VDC nominal voltage with Reverse polarity, transients including load-dump, over-voltage, and ESD

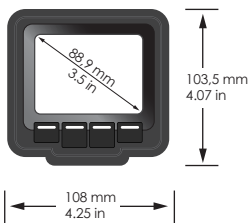

32 bits ARM processor, with 8-32 MB DDR RAM (Scalable)
16-128 MB NAND Flash memory for Data (Scalable)

TFT direct sunlight readable.
LED back-lighted display

Housing - Nylon, ABS-PC
4 soft keys with LED illumination and tactile feedback
Buzzer - for sound notifications

Weight: 0.2 kg (0.45 lb)

Environmental Specifications

- EMC Conformity: ISO 13766
- IP66 ingress protection
- Voltage: 12 or 24 V
9 - 32 VDC operating range
- Temperature range:
-40°C to +70°C
(-40°C to +80°C storage)



HMI VC 5.0

Freely programmable, multifunctional display

Linux HMI VC is a 5.0" full-color display with a powerful ARM CPU. The open software platform has a choice of tools for design of premium graphical user interfaces. This, together with WVGA display resolution and high brightness display, enables fast design of sharp interfaces with high usability.

With touch screen and configurable soft keys, operators are offered a user friendly interaction with the system. Linux HMI VC has multifunctional capability and can be used as instrumentation display, control system GUI, video monitor, Service tool and more.

DISPLAY	
TYPE	TFT with LED backlight and anti-glare coated glass
SIZE AND RESOLUTION	5.1" WVGA, 800 x 480 pixels
COLOR DEPTH	24 bit
BRIGHTNESS	650 Cd/m ²
DIMMING	Automatic dimming through ambient light sensor. Dimming can be controlled manually via soft keys and/or touch screen
OPTICAL BONDING	TFT and glass optically bonded. Optical bonding is optional.
HMI	
TOUCH SCREEN	Type: Resistive. Touch screen is optional.
SOFT KEYS	8 soft keys, configurable. Soft keys can be used as function keys for the GUI, to control Power On/Off, to control display brightness etc. Soft keys are optional.
BUZZER	For alarms and notifications
INTERFACES	
CAN	2 x CAN. ISO11898 2.0B, bitrate configurable 20 – 250 kbps.
ETHERNET	1 x Ethernet. 10/100 Base-T.
USB	2 x USB 2.0. 1 in Deutsch connector and 1 mini-USB under cover on rear side for software upgrading.
VIDEO	1 x Analog Video input. NTSC or PAL.
KEY SWITCH	1 x Key switch input, for start-up/shut down
INPUTS	2 configurable inputs for analog/digital sensors. May be used for measuring resistance/4-20mA/frequency/digital/analog signals.
OUTPUTS	2 configurable high side outputs for driving up to 1A. May be used for continuous driver or PWM output.
POWER SUPPLY	12 or 24 VDC nominal voltage

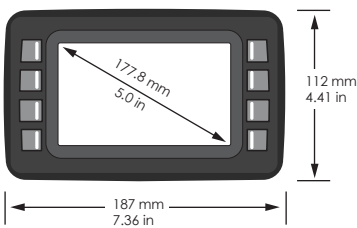

32 bits ARM processor, with 256 MB DDR3 RAM (Scalable)
512 MB NAND Flash memory for Data (Scalable)

TFT display with anti-glare coated glass and Automatic Dimming.
LED back-lighted display
(Optional touch screen)

Housing - Plastic
8 application controlled soft-buttons
Buzzer - for sound notifications

Weight: 0.425 kg (0.94 lb)

Environmental Specifications

- EMC Conformity: 2004/108/EC, EN61000-6-2:2005,
- IP66 ingress protection
- Operating supply voltage range: 12 or 24 V
- Operating temperature range: -40 to +70°C
(-40°C +85°C storage)



Linux HMI VA is a freely programmable, ARM-based display computer with 7.0" full-color TFT and touch screen.

Designed for advanced HMI functions in cost sensitive industrial vehicle applications, Linux HMI VA can integrate several HMI functions like instrumentation, process GUI and video. The wide screen display offers good readability also in direct sunlight and the open software application platform enables easy realization of appealing user interfaces. It is suitable for both bracket mounting and integration in a dashboard. The interaction concept supports any combination of touch screen and programmable keys.

		STANDARD
DISPLAY	7" WVGA, 800 x 480, 18 bit color depth, 700 cd/m ²	•
INTERFACES		
- CAN	CAN, ISO 11898 2.0B, Bit-rate configurable 20–250 kbps. (1Mbit optional)	2 x
- ETHERNET	1 x 10/100 Base-T	•
- SERIAL	1 x RS232	•
- USB	1 x USB 2.0	•
- DIGITAL I/O	4 x Configurable as in or out	
- VIDEO IN	Analog Video in, NTSC or PAL	2 x
- AUDIO	Stereo line out	
- WLAN	Built-in 801.11 b/g	
- GSM/GPRS	Built-in GSM/GPRS modem	
- BLUETOOTH	Built-in HCI Bluetooth	
- GPS	Built-in GPS receiver	

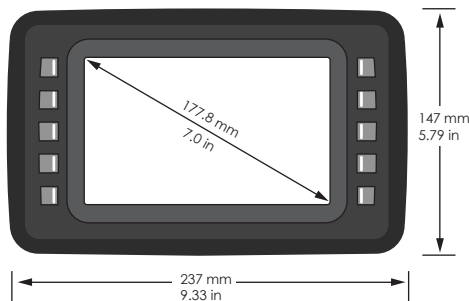

32 bits ARM processor, with 256 MB DDR3 RAM (Scalable)
512 MB NAND Flash memory for Data (Scalable)

TFT display with anti-glare coated glass and Automatic Dimming.
LED back-lighted display
(Optional touch screen)

Housing - Plastic
10 application controlled soft-buttons
Buzzer - for sound notifications

Weight: 0.6 kg (1.32 lb)

Environmental Specifications

- EMC Conformity: 2004/108/EC, ISO 14982:2009
- IP66 and IP67 ingress protection
- Voltage: 12 or 24 V
9 - 32 VDC operating range
- Temperature range:
-25°C to +70°C
(-40°C to +85°C storage)
- Vibrations: 0,01g²/Hz 10-200 Hz
- Shock: 5 g/11 ms 3x ±1000 bumps



HMI XA 7.0

Touch screen display and controller

Linux HMI XA is an ARM-based touch screen display and controller for creating a premium user experience in cost sensitive industrial vehicle applications.

The wide screen display with all-glass PCAP touch screen offers good readability also in direct sunlight and the open software application platform enables easy realization of appealing user interfaces.

		VALUE	STANDARD	ALL-INTEGRATED	NET + STANDARD	NET + ALL-INTEGRATED
DISPLAY	7" WVGA, 800 x 480, 18 bit color depth, 700 cd/m ²	•	•	•	•	•
INTERFACES						
- CAN	CAN, ISO 11898 2.0B, Bit-rate configurable 20–250 kbps. (1Mbit optional)	2 x	2 x	2 x	4 x	4 x
- ETHERNET	1 x 10/100 Base-T	•	•	•	•	•
- SERIAL	1 x RS232	•	•	•	•	•
- USB	1 x USB 2.0	•	•	•	•	•
- DIGITAL I/O	4 x Configurable as in or out		•	•	•	•
- VIDEO IN	Analog Video in, NTSC or PAL	2 x	4 x	4 x		
- AUDIO	Stereo line out		•	•	•	•
- WLAN	Built-in 801.11 b/g			•		•
- GSM/GPRS	Built-in GSM/GPRS modem			•		•
- BLUETOOTH	Built-in HCI Bluetooth			•		•
- GPS	Built-in GPS receiver			•		•

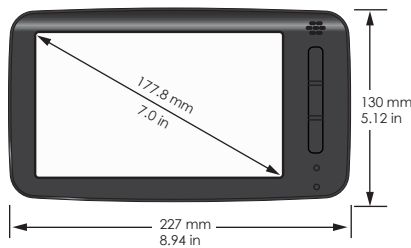

32 bits ARM processor, with 256 MB DDR3 RAM and up to 4 GB Flash memory for Data.

TFT display with LED backlight and Automatic Dimming.

Housing - Aluminum (Plastic for XA Value model)
 3 Push-buttons, On/Off increase/decrease light
 Status LED - Application controllable in front panel
 Buzzer - for sound notifications

Weight: 1.1 kg (2.43 lb)

Environmental Specifications

- EMC Conformity: 2004/108/EC, EN61000-6-2:2005, EN61000-6-4:2007, ISO 14982:2009
- IP65 ingress protection
- Voltage: 12 or 24 V
- Operating temperature range: -25 to +70°C (-40°C +85°C storage)
- Vibrations: 0,01g²/Hz 10-200 Hz
- Shock: 5 g/11ms 3x ±1000 bumps



Touch screen display computer

HMI XS 10.4, 12.1

Linux HMI XS is an ARM-based touch screen display computer that provides the screen capabilities, interfaces and computing power to form integrated HMI systems for industrial vehicles.

The open software application platform for GUI, controls, diagnostics and mobile connectivity enables easy realization of total vehicle HMI systems.

		STANDARD	ALL-INTEGRATED	NET+ STANDARD	NET+ ALL-INTEGRATED
DISPLAY	10.4" XGA, 1024 x 768, LED, 480 cd/m ²	•	•	•	•
	12.1" XGA, 1024 x 768, LED, 400 cd/m ²	•			
INTERFACES					
- CAN	CAN, ISO 11898 2.0B, Bit-rate configurable 20–250 kbps. (1Mbit optional)	2 x	2 x	4 x	4 x
- ETHERNET	1 x 10/100 Base-T	•	•	•	•
- SERIAL	1 x RS232	•	•	•	•
- USB	1 x USB 2.0	•	•	•	•
- DIGITAL I/O	4 x Configurable as in or out	•	•	•	•
- VIDEO IN	4 x Analog Video in, NTSC or PAL	•	•		
- AUDIO	Stereo line out	•	•	•	•
- WLAN	Built-in 801.11 b/g		•		•
- GSM/GPRS	Built-in GSM/GPRS modem		•		•
- BLUETOOTH	Built-in HCI Bluetooth		•		•
- GPS	Built-in GPS receiver		•		•

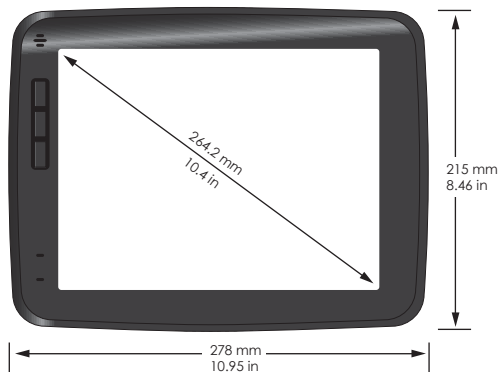

32 bits ARM processor, with 512 MB DDR3 RAM and 4 GB Flash memory for Data.

TFT display with LED backlight (4:3) with antiglare coating, and Automatic Dimming - available in 10" and 12" models

Housing - Aluminum

3 Push-buttons, On/Off increase/decrease light

Status LED - Application controllable in front panel

Buzzer - for sound notifications

Weight: 10" - 2.2 kg (4.85 lb) 12" - 3.1 kg (6.83 lb)

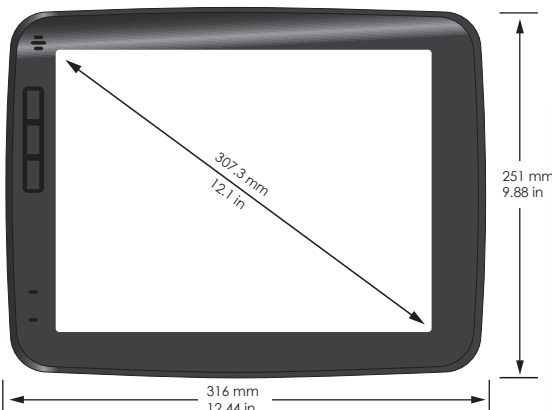

Environmental Specifications

- EMC Conformity: 2004/108/EC, EN61000-6-2:2005, EN61000-6-4:2007, ISO 14982:2009
- IP65 ingress protection
- Operating supply voltage range: 12 or 24 V
- Operating temperature range: -25 to +70°C (-40°C +85°C storage)



Serving Industry Leading Companies for more than 50 years.

Kubota

AM General

DOOSAN

**HONDA
MARINE**



KOHLER

CHAPARRAL

Husqvarna

SUZUKI

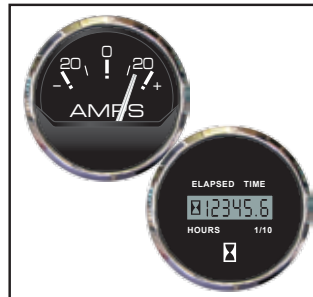

POLARIS

Onan

**EXCEL
INDUSTRIES**

OSHKOSH



**TOHATSU
Outboards**

Bad Boy

BRP

**LOFA
INDUSTRIES INC.**

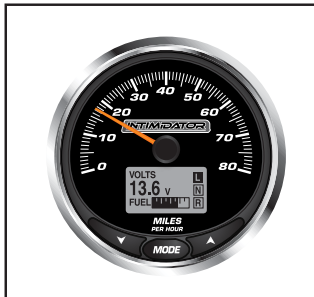

Made in the USA

Faria Beede Instruments, Inc.
 P. O. Box 983 88 Village Street
 Uncasville, CT 06382 Penacook, NH 03303
 860.848.9271 603.753.6362
 Fax: 860.848.2704 Toll-free: 800.451.8255
 Fax: 603.753.6201

Manufactured by the Faria Beede Instruments, Inc., Uncasville CT, Penacook, NH, USA • Copyright and all other rights reserved.
 Our products are continually being improved. Specifications may change without notice.

fm-002-0044 B 05/2015