

HONDA

Installation Instructions

INSTALLATION INSTRUCTIONS

Accessory
TACHOMETER
ASSEMBLY COMPLETE

P/N 37250-ZV5-950AH
H/C 4477675

Application
OUTBOARDS

BF75, BF100, BF8
BF9.9/15, BF25, BF35/45

Publication No.
PII 51362

Issue Date
January 1994

GENERAL INFORMATION

FOLLOW THESE INSTRUCTIONS CAREFULLY. Proper installation is essential for safe, reliable operation. While performing these procedures, use adequate safety equipment and protective apparel such as gloves, safety glasses or faceshield, and safety shoes as needed.

PARTS LIST

Remove all parts from the carton, and check all parts against the following list.

ITEM	QTY.	DESCRIPTION	ITEM	QTY.	DESCRIPTION
①	1	Tachometer (0 ~ 7000 rpm)	③	1	Mounting Bracket
②	1	¼ inch Female Connector	④	2	#10 Brass Flat Washers
			⑤	2	#10 Stainless Split Lockwashers
			⑥	2	10-32 Brass Nuts
			⑦	1	T-10 Connector with 6½" wires

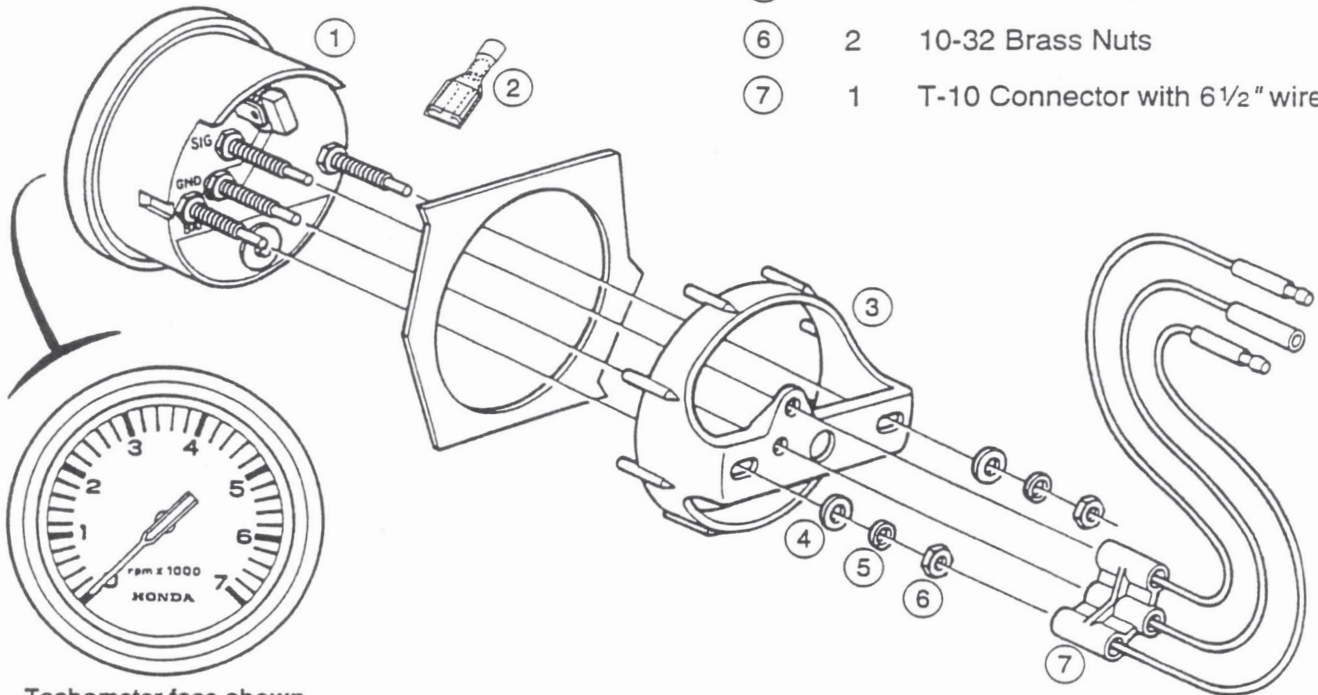

Tachometer face shown with 12Vdc power ON.

FIGURE 1

Order the following meter harnesses as needed:

Remote control types:

Meter harness assembly A — is included with the LRTA and SRTA type outboards. This harness connects to the remote control box wiring harness. It has the electrical connector provisions to connect a tachometer, trim meter, light switch, and meter harness assembly B.

Non-remote control types:

At this time, there is no complete wire harness available to connect the pulse from the charge coil and 12Vdc power to the tach. A sub harness (P/N 32197-ZH8-003) can be ordered to help simplify installation. On the LHTA type, the tach connects to the main harness.

PREPARATION FOR INSTALLATION

1. Disconnect the negative battery terminal.
2. The tachometer should be located a **minimum** distance of 130 mm, case-to-case, from a magnetic compass. The 130 mm spacing should be considered a minimum distance. If at all possible, the tachometer should be mounted as far as possible from any compass, especially very sensitive ocean-going models. Select a mounting location which provides easy readability from the operator's position. Check behind the mounting panel for sufficient installation clearance.

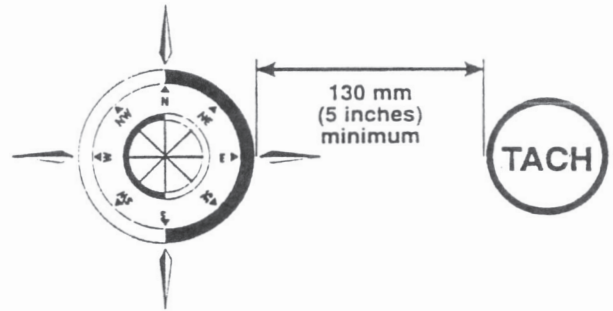

It is also suggested that any compass be recalibrated when a tachometer is installed or removed.

Also, some interference (erratic operation) may be noticed on the tachometer during radio transmissions. This will neither damage the tachometer nor affect accuracy when not transmitting.

3. Be certain to use stranded, insulated wire not less than 18 gauge that is approved for marine use. It is recommended that insulated wire terminals be used on all connections to the tachometer.
4. Using a small screwdriver, SLIGHTLY depress and turn the selector switch on the back of the tachometer to the correct position to match the number of poles in the alternator. Depressing the switch too hard may cause damage to the tachometer. Be sure the selector switch has locked into the detent at the correct position by slightly rotating the switch back-and-forth with the screwdriver.

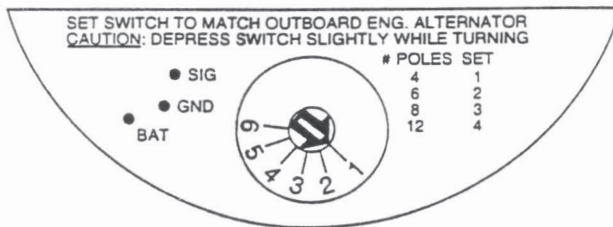

Outboards	# Poles	Switch Setting
BF75	4	1
BF100	4	1
BF8	4	1
BF9.9	4	1
BF15	4	1
BF25	4	1
BF35	6	2
BF45	6	2

5. Cut a 3³/₈ inch (86 mm) diameter hole through the panel at the desired location.
6. Insert the tachometer into the mounting hole in the panel and check the fit.
7. Fit the mounting bracket over the mounting studs (refer to Figure 1 on page 1 of 4).

The mounting bracket is made to install tachometers in panels up to 1/2 inch (13 mm) thick. The round tabs on the mounting bracket can be removed to gain an additional 1/4 inch (6 mm) if necessary.

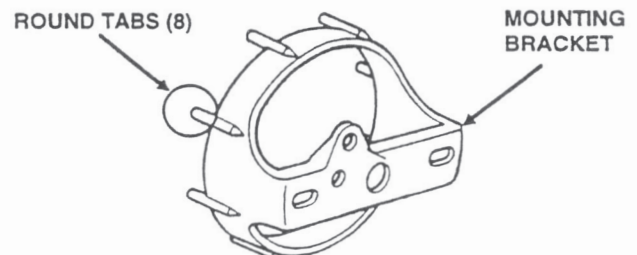

TACHOMETER INSTALLATION

1. After checking the tachometer fit in the panel, install the mounting bracket over the mounting studs.
2. Install a flat washer, split washer and nut onto the mounting studs as shown below. Tighten nuts only slightly more than you can tighten them with your fingers. Six inch pounds of torque is sufficient. Overtightening the nuts may result in damage to the instrument and may void your warranty.

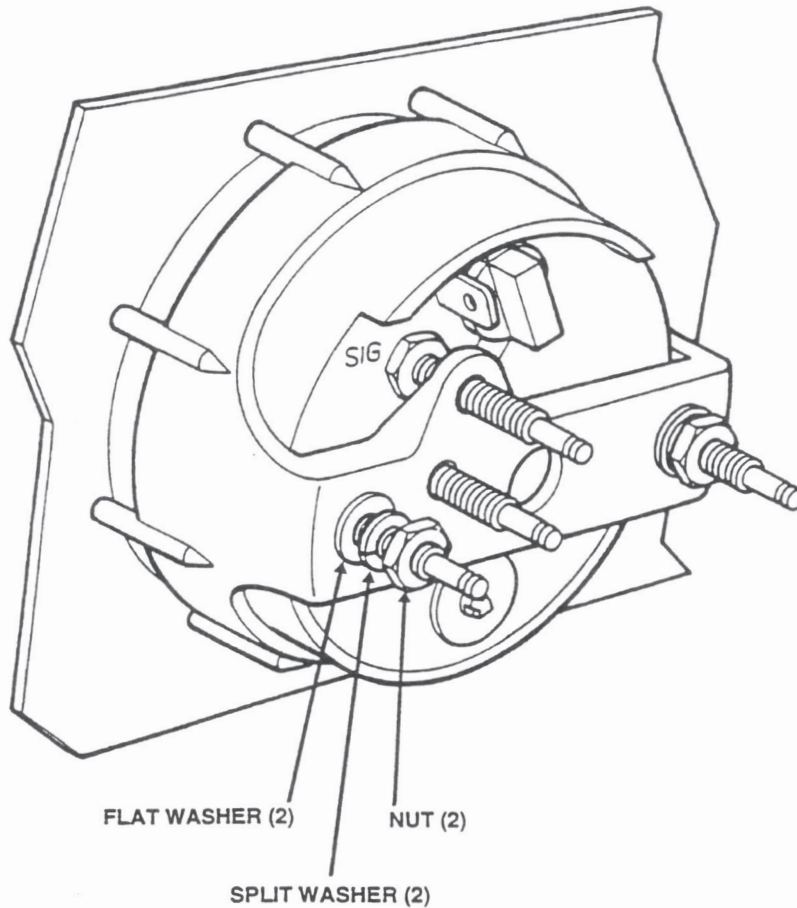

ELECTRICAL CONNECTIONS

Remote Control Types

1. Remove the female connector from the red/white wire of meter harness assembly A. Crimp-on the supplied $\frac{1}{4}$ inch female connector as shown below.

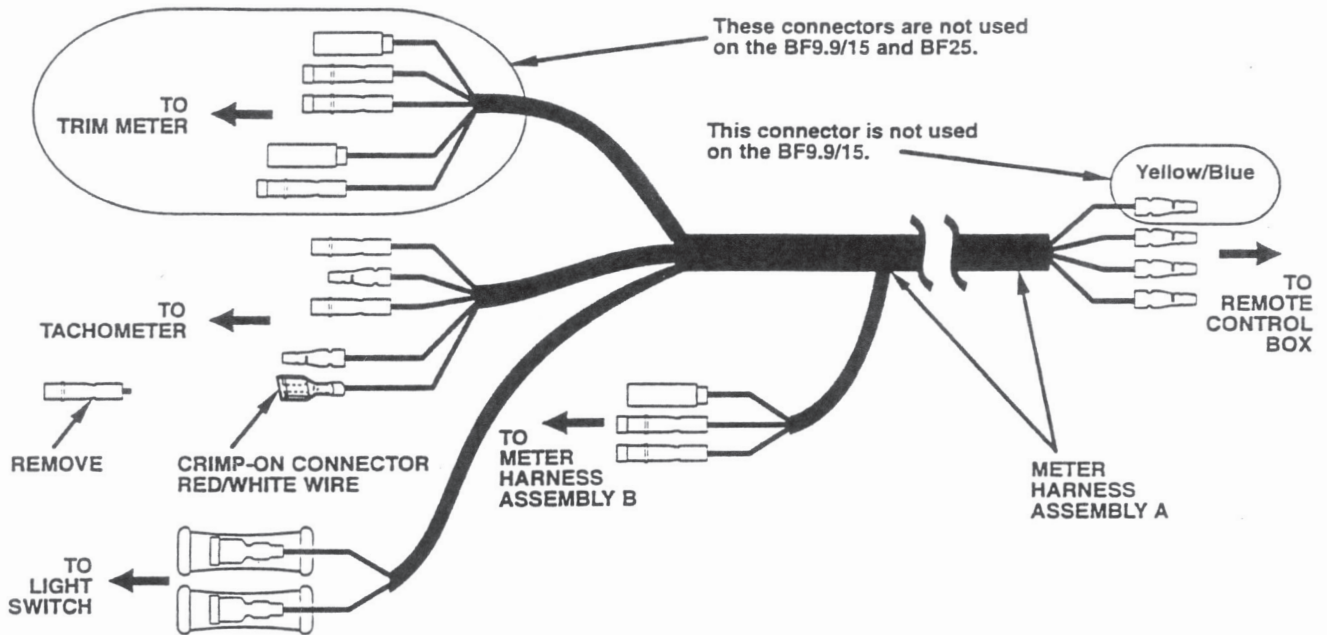

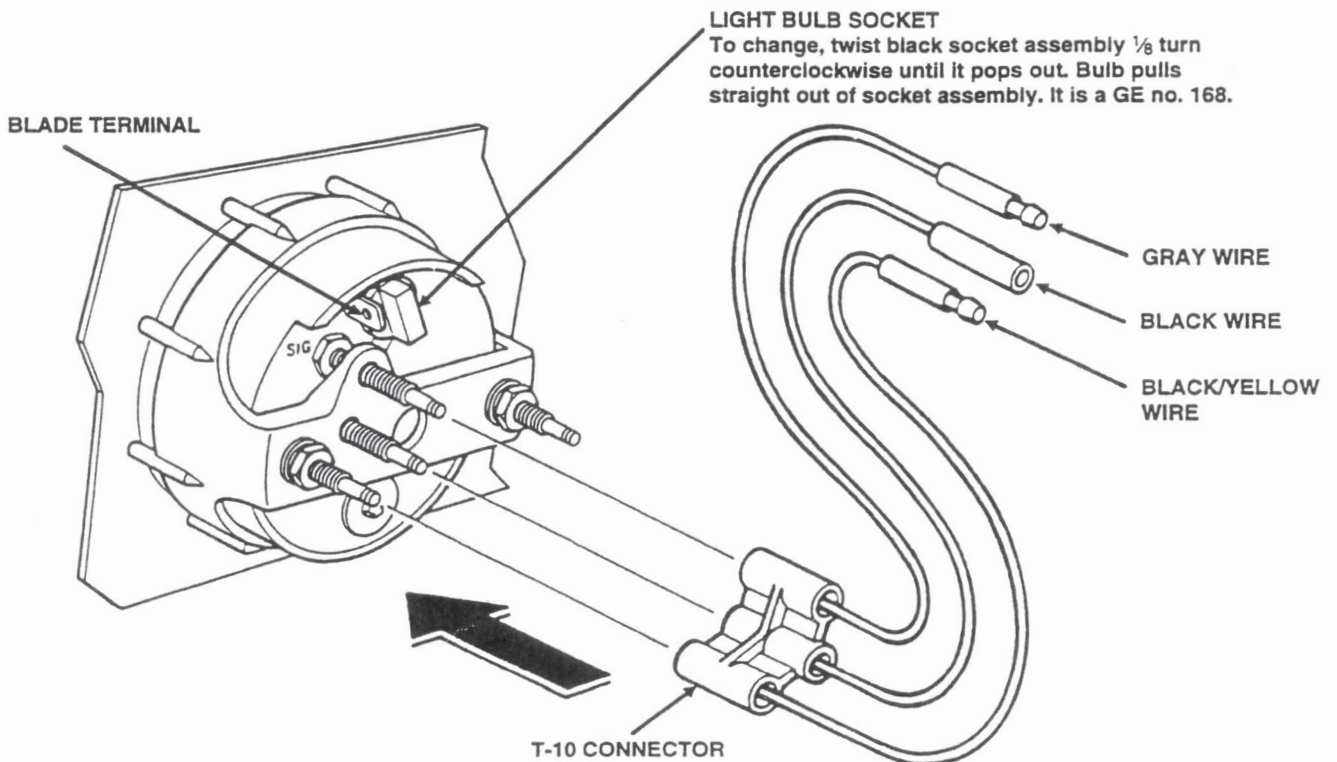

2. Plug the T-10 connector onto the three tachometer studs as shown. Connect the red/white (+) wire, with the newly installed $\frac{1}{4}$ inch female connector, to the blade terminal adjacent to the twist-out light bulb socket. No separate ground is required for lighting.



ELECTRICAL CONNECTIONS (continued)

Non-Remote Control Types

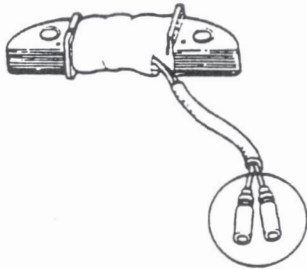
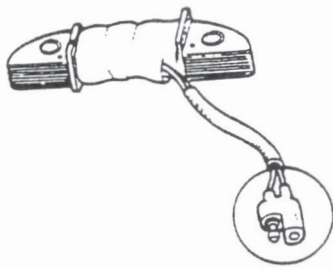
The following modification is necessary for the BF75 and BF100 outboards. This modification is also necessary for the BF8 prior to frame serial number BACS/BACL 1200000. Remove the dual connectors from the charge coil and rectifier then install individual connectors as shown below. Use Honda Wire Terminal Kit (H/C 0252437) to simplify installation.

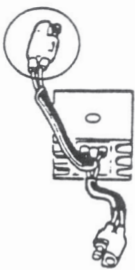
Item	Model	
	BF75 and BF100 BF8 prior to frame serial number BACS/BACL 1200000	
	After modification	Before modification
Charge coil		
Rectifier		

Make a parallel connection between the tachometer gray wire and either one of the ac charge coil wires. To make the charge coil connection, you can either make your own sub harness or order the sub harness shown below.

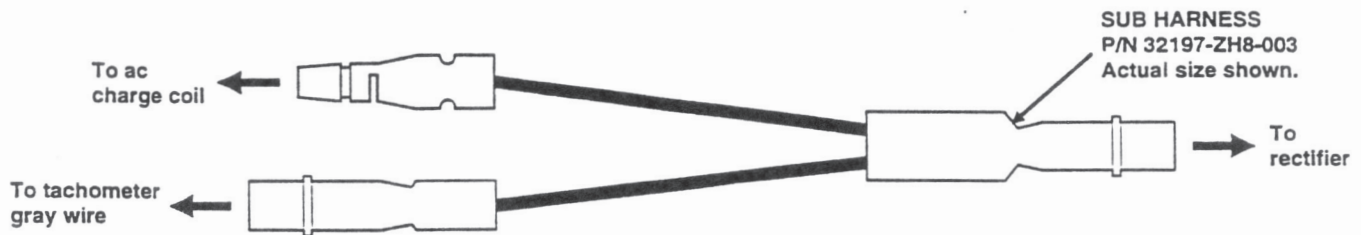

Connect the black wire from the tachometer to the boat's electrical ground. Connect the black/yellow wire from the tachometer to a 12Vdc circuit that is fused and controlled by the ignition switch. Using the 1/4 inch female connector provided, connect the blade terminal adjacent to the twist-out light bulb socket to the instrument light switch. No separate ground is required for the instrument light.

For the tachometer to register, it is necessary to connect the outboard engine to the boat's electrical ground. The DC receptacle, when connected to the battery, will provide the necessary circuit between the engine and the boat's electrical ground.

On the LHTA type, the tachometer connects to the main harness.

