



Fuel Management System

Owner's Manual

- Displays Fuel Flow in GPH or LPH
- Total or Trip Fuel Used
- Low Fuel Alarm
- Calculates Fuel Remaining In Tank
- Gas Engines Only

IS0125

rev. E
ECR#7218 03/2008

Contents

Specifications	4
Installation.....	5
Location	5
Wiring Connection.....	6
Installation of the Fuel Flow Transducer	6
Instrument Setup	7
Select units of measure	7
Flow Averaging	8
Fuel Flow	9
Fuel Remaining Functions	9
Change Fuel Remaining value.....	1
Set Low Fuel Alarm.....	10
Alarm activation	10
Reset TRIP LOGs	10
Troubleshooting Chart	11
No display	11
No flow reading indicated.....	11
Low flow reading indicated.....	11
No fuel reading	11
High or erratic reading	11

Specifications - For use with gas engines only.

Size

Mount 21/16" diameter hole
Depth behind face plate 3" min
Display 3-character LCD

Backlighting

Red colored diffused lighting for display.

Water Integrity

Front will withstand direct water spray.

Alarm

Audio and visual alarms indicate the remaining fuel total has dropped below a preset alarm value

Flow

0.5 to 34 US gallons per hour
2 to 129 liters per hour
0.4 to 28 imperial gallons per hour
The instrument may show erratic readings or indicate 0 flow below .5 gph.

Logs

Logs record fuel used up to 999 display units.
Both Trip Log and Total Log are saved in memory at power down. Both Trip Log and Total Log can be reset.

Fuel Remaining

User enters a fuel value into memory. The quantity of fuel used is automatically subtracted from the total. This value remains in memory at power down.

Operating Voltage

8 VDC to 16.5 VDC

Operating Temperature

0°C to 50°C (32°F to 122°F)

Current Drain

90 mA max. with supplied transducer.

Compliance/Certifications

<6 dB quieting on any marine radio channel (with 3 dB gain antenna) within one meter of the instrument. Complies with CE EMC standards EN50081-1 and EN50082-1 and FCC Section 15.
Complies with International Standard ISO 8846:1990(E).

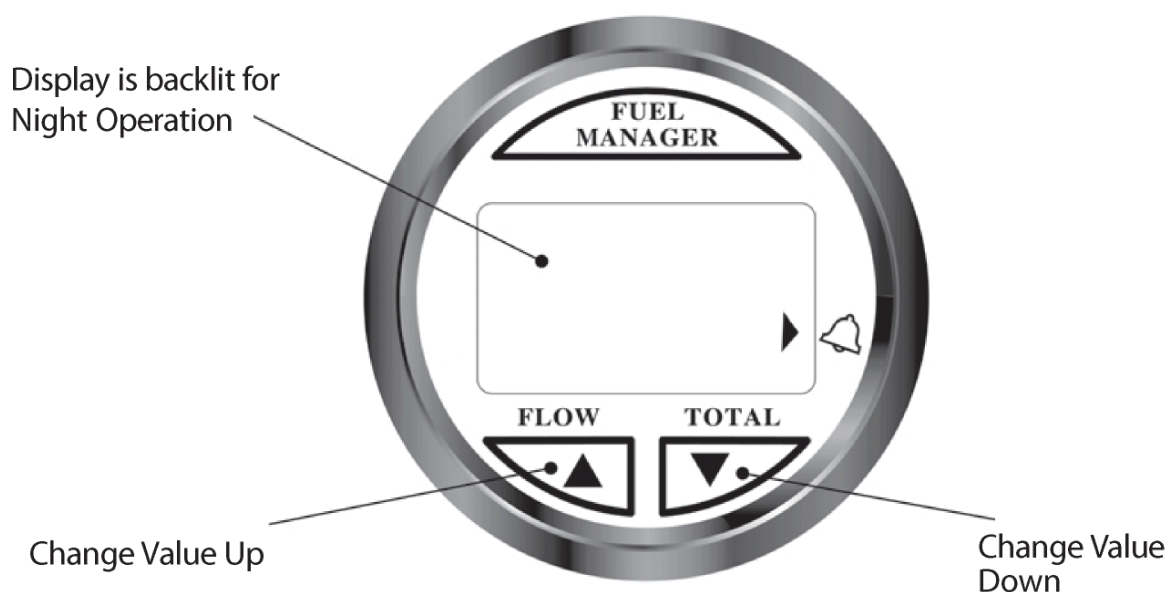

IMPORTANT

Always install the Fuel Flow Transducer AFTER the primary filter. The primary filter must be a good quality water separator type with a minimum filtration of 30 microns or better. (10 or 2 micron. The lower the micron rating the finer the filtration) Failure to provide this level of filtration protection will result in inaccurate readings or total failure or damage to the transducer. If there is not a suitable length of hose after the primary filter, an in-line filter (30 micron or better) should be fitted before the Fuel Flow transducer. Damage due to insufficient filtration is not covered by warranty. If in doubt, please consult your local Marine dealer for advice prior to installation.

Installation

Always wire your Fuel Management Gauge into your boats ignition so that when the engine is turned on, the gauge is recording the fuel used. If an accessory switch is used and you forget to turn the unit on then the gauge will not have recorded the fuel used and will be inaccurate. If you are unsure how to do this, contact a qualified marine electrician.

Location

The Fuel Management Gauge is designed for above or below deck installation. Select a position that is:

- On a flat surface
- At least 12" from a compass
- At least 20" from any radio
- Easy to read by the helmsman and crew
- Protection from physical damage
- Accessible to electrical cable connection

Mounting

- The instrument panel may be up to $\frac{3}{4}$ " in thickness.
- Drill a $2\frac{1}{16}$ " hole in the instrument panel.
- Remove brackets and insert the instrument so the back is flush with the instrument panel.
- Slide the back clamp over the instrument and tighten mounting nuts until secure.

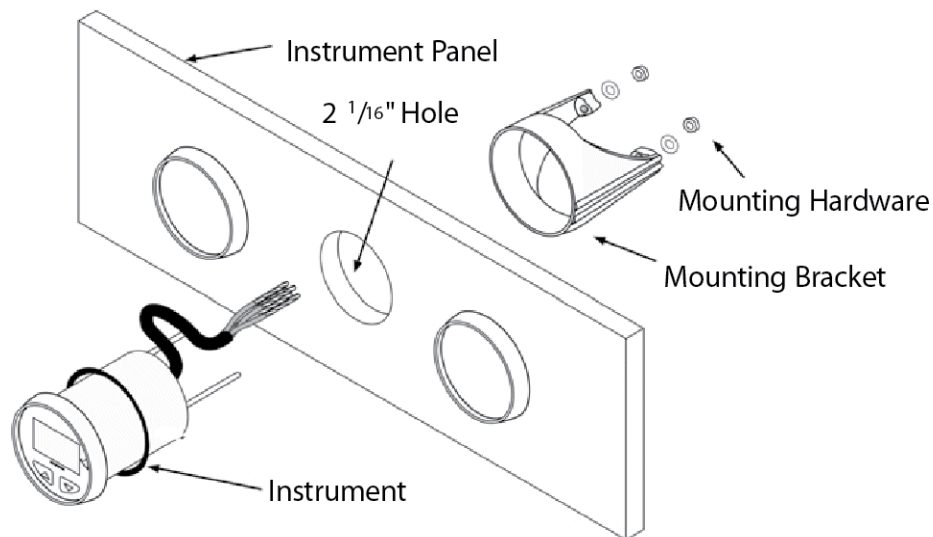

Wiring Connection

- Keep electrical and transducer cables away from alternator or other noise generating electrical cables. Avoid connecting the instrument to power circuits that share loads with ignition, alternators, inverters and radio transmitters. Electrical power supply connections should always be as short as possible.
- Connect the fuel flow transducer to the gauge as follows:
- Connect the red wire from the gauge to the positive supply through a 1 amp fuse or a 1 amp circuit breaker. Connect the green wire from the gauge to the electrical ground.

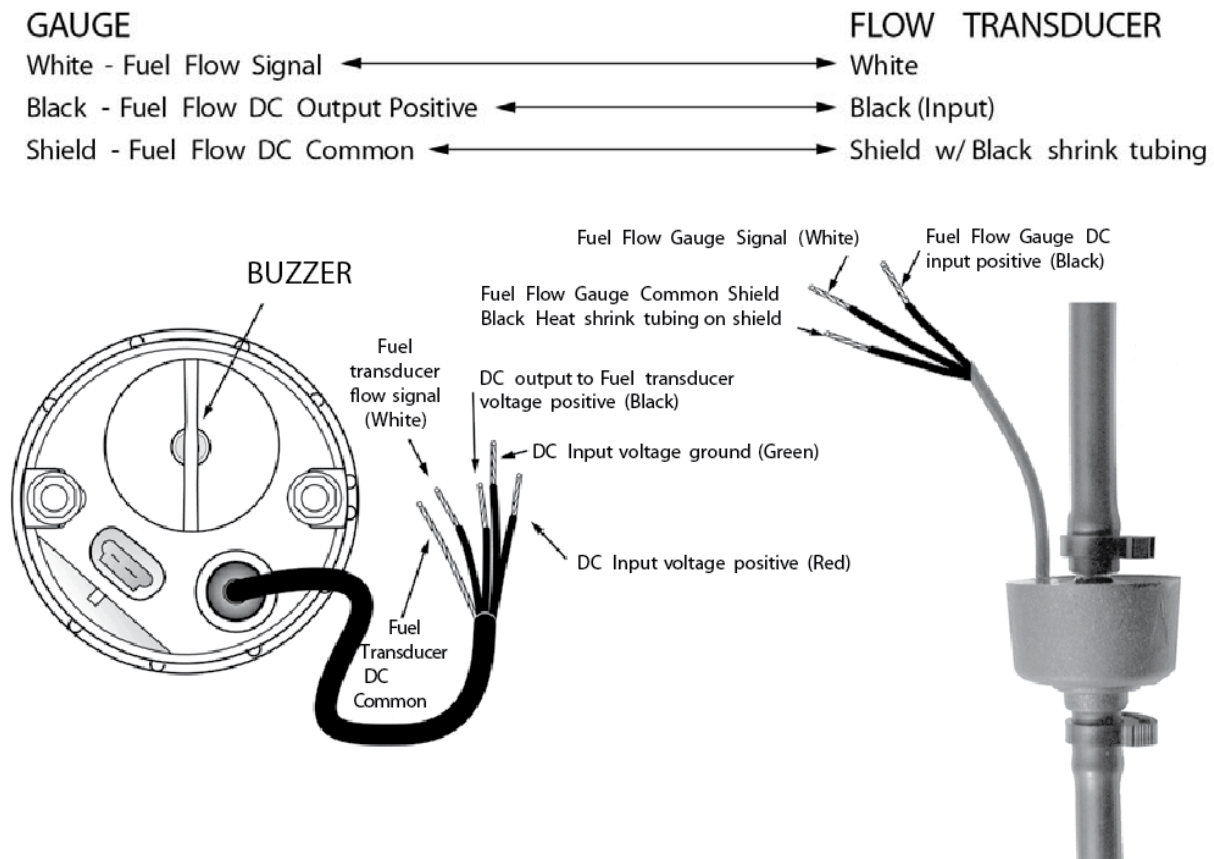

Installation of the Fuel Flow Transducer

The fuel flow transducer is designed for installation in Coast Guard approved $\frac{3}{8}$ " flexible fuel line. The transducer **MUST** be installed **AFTER** the main fuel filter. It should be located well away from any area where it will be affected by excessive heat or vibration from the engine. It is preferable to mount the transducer in a vertical position.

Drain all the fuel from the flexible fuel line. Cut the fuel line and using the fuel hose attaching clips provided install the transducer so that the **FUEL IN** side of the transducer connects to the fuel tank.

Instrument Setup

Select units of measure

The Fuel Management fuel flow meter can display fuel values in US gallons, Liters or Imperial gallons. To change the current display setting, perform the following steps.

1. Power up the unit while holding  key.



Press and hold during power up

2. Once the unit is on, release the key.

The current display setting is indicated as pictured below:

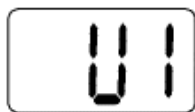

Imperial Gallons

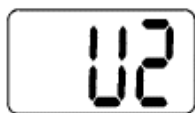

US Gallons

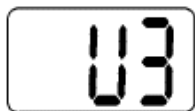

Liters

3. To select another display setting, use the up or down keys to change the value.

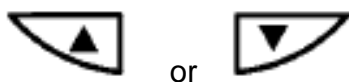

4. To save the change and exit this mode, press and hold both keys simultaneously for one second.



Press and hold for one second

The fuel values are now displayed using the new setting.

Calibration

The fuel transducer supplied with the fuel flow meter will provide readings at better than 5% accuracy. Individual calibration will increase this level of accuracy to better than 2% over a fuel flow range of 2 to 32 US gallons per hour.

While a properly calibrated unit should provide accuracy within the published limits, the user should also have a level sender or fuel level gauge installed in the boat. This is necessary due to possible operator induced errors such as forgetting to reset the fuel used when filling the tank, or other operator controlled actions that may render the device inaccurate. Perform the following steps to calibrate your fuel flow meter:

1. Reset the total log value to zero(see pg 9)
2. Use a known amount of fuel. The larger the amount the more accurate the calibration will be.
3. Take note of the actual volume of fuel used and the fuel used indicated by the total log. If these two totals are different, the instrument may require calibration.

4. Apply power while holding  key.



Press and hold while applying power

5. Release the key. The display flashes the current total log value.



6. Use the up or down key to change the display and indicate the actual volume of fuel used.

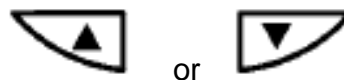

7. Press both keys simultaneously and hold for 2 seconds to exit.



Press and hold for 2 seconds

The fuel flow meter is now calibrated.

AVG (which shows as **AUG**) is displayed. To skip this function and return to normal mode, hold both keys simultaneously for another 2 seconds

Flow Averaging

The Flow Averaging function sets the time period over which the fuel flow is averaged. The time period can be set in the range of 1 to 99 seconds. Normally, engines do not draw fuel from the tank at a constant rate. An engine draws fuel at a high rate for a short time until the carburetor bowl or injection reservoir is full and then draws no fuel for a few seconds. If the true flow rate were displayed, it would be too erratic to read.

Usually, a value of 10 -15 seconds gives satisfactory results for two stroke naturally carbureted engines. Four stroke and engines that use electronic fuel injection may require longer periods. If the readings seem erratic, you can increase the time period.

A long time period means the fuel display will have a slow response time and a more accurate reading. A short time period means the display will have a quick response time but an erratic display reading. The flow time period setting only affects the fuel flow display. It does not affect the fuel used or fuel remaining measurement in terms of accuracy.

Flow Average Menu

Follow the steps outlined below to enter the Flow Averaging Menu:

1. Press and hold the ▲ key while applying power to enter the Fuel Calibration menu.



2. Press and hold both keys simultaneously for 2 seconds to enter the Flow Filter mode.



3. The Fuel Flow Average Period menu **AVG** is displayed briefly and then the default value of **10** seconds is displayed if you have not previously changed it.



4. Use the up or down keys to change the value between 1 and 99 seconds.

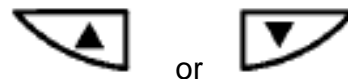

5. Press and hold both keys simultaneously for 2 seconds to save the new averaging time period and return to normal operation



Operation

Fuel Flow

Press the ▲ key to display the current fuel flow rate

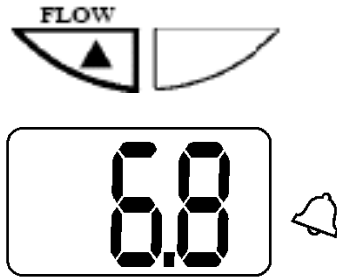

Fuel Remaining Functions

Press the ▼ key to cycle through the possible functions. Each time the key is pressed the an identifier is displayed for 2 seconds before the value is displayed.

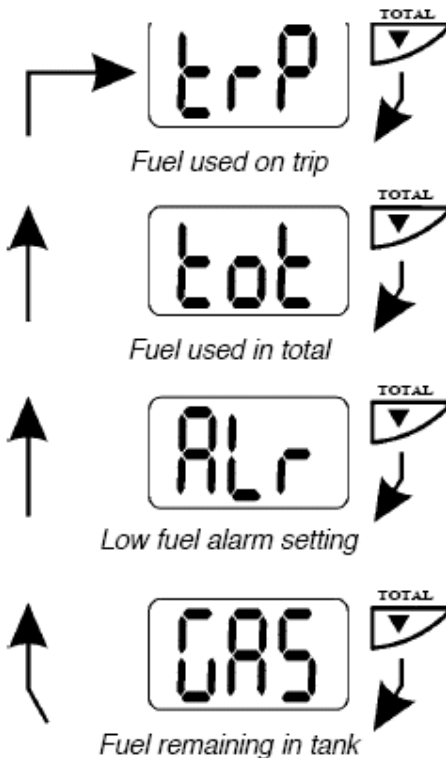

Change Fuel Remaining

To change the value of fuel remaining in the tank press the ▼ key until **GAS** is displayed.



After 2 seconds, the current value is displayed.



Press and hold both keys for 2 seconds



The display begins to flash.



Use the up or down keys to change the value.

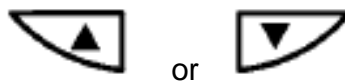

Press and hold both keys for 2 seconds to save this new value to memory and to exit this function.

GAS is displayed and then the new value.

Alarm activation

Set Low Fuel Alarm

To set the Low Fuel alarm, press ▼ key



until ALr is displayed



After 2 seconds, the current alarm value is displayed.

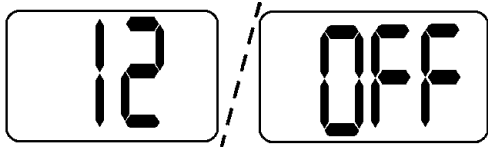

If no alarm value has been entered, OFF is displayed

Press and hold both keys for 2 seconds until the display flashes.

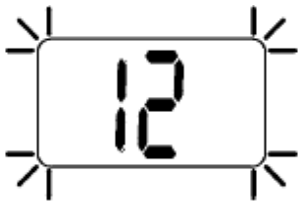

Use the up or down keys to change the value.

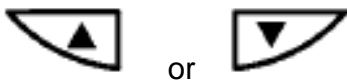

Press and hold both keys for 2 seconds to save this new value to memory and exit this function.

ALr is displayed and then the new value with an arrow pointing at the alarm bell.

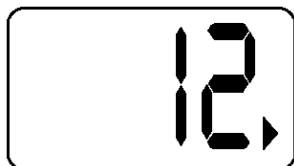

When the fuel remaining value drops below the fuel alarm value, the alarm sounds and the alarm arrow flashes.



Press any key to mute the alarm. The alarm arrow continues to flash as long as the alarm condition remains.

Reset TRIP LOGs

To reset a log, press the ▼ key until the display indicates the name of the log to be reset.

Press and hold both keys for 2 seconds.



The display shows trP or tot or for 2 seconds before resetting to zero.

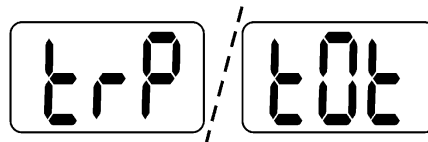

The trip log value may be reset without changing the total log value. if the total log is reset to zero, then the trip log will automatically reset to zero.

Note: If the total log exceeds 999 then both it and the trip log will be reset to zero.

Troubleshooting Chart

No display

- 1 Check DC power connections and DC polarity with voltmeter
- 2 Check fuse

No flow reading indicated

- 1 Check connection to flow transducer
- 2 Remove transducer from fuel line, blow through transducer and a whistling noise will indicate the turbine is rotating.

Low flow reading indicated

- 1 Check your primary and secondary filters for obstructions. If no filters are fitted this will lead to blockage and damage of flow transducer (see page 5).
- 2 Check that the calibration is correct.

No fuel reading

- 1 Check your primary and secondary filters for obstructions. If no filters are fitted this will lead to blockage and damage of flow transducer (see page 5).

High or erratic reading

- 1 Check fuel connections are well made. Air in fuel lines will cause erratic or high readings.

Copyright 2005 by the Thomas G. Faria Corporation, Uncasville CT
Faria® is the trademark of the Thomas G. Faria Corporation. All rights reserved. No part of this publication may be reproduced in any form, in an electronic retrieval system or otherwise, without the prior written permission of the company.