

Owner's Manual

Fuel Management System

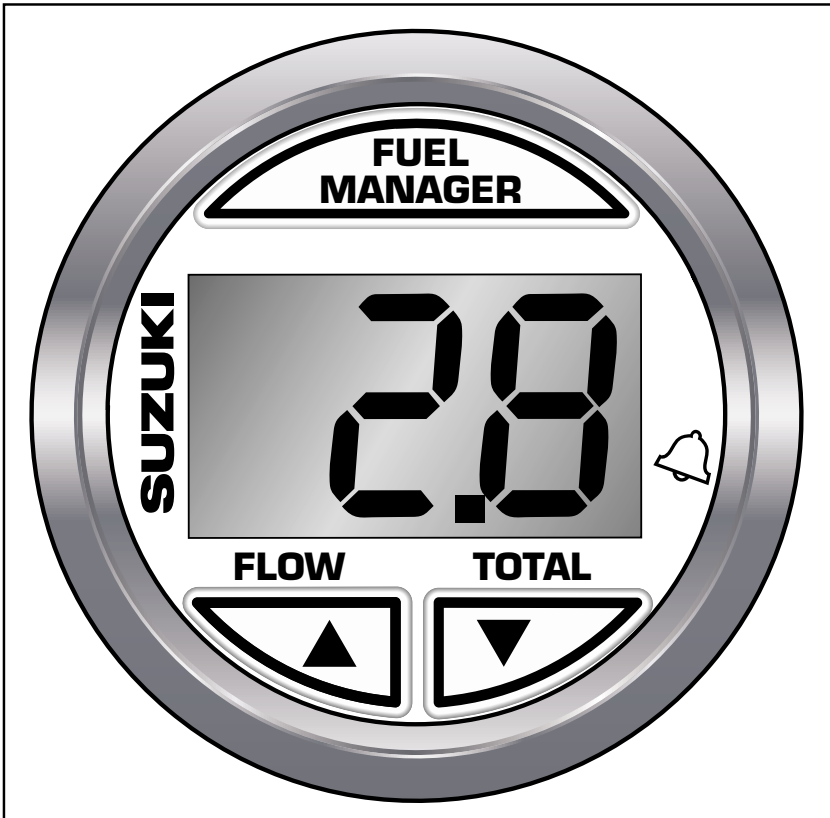

- Displays Fuel Flow in GPH or LPH
- Total or Trip Fuel Used
- Low Fuel Alarm
- Calculates Fuel Remaining In Tank
- Gas Engines Only

Important

 **WARNING**

 **CAUTION**

NOTE

Please read this manual and follow its instructions carefully. To emphasize special information, the symbol  and the words **WARNING**, **CAUTION** and **NOTE** have special meanings. Pay special attention to the messages highlighted by these signal words:

NOTE: *Indicates special information to make maintenance easier or instructions clear.*

 **WARNING**

Indicates potential hazard that could result in death or injury.

 **CAUTION**

Indicates potential hazard that could result in vehicle damage.

Table of Contents

Specifications	Page 4
Installation	Page 5
Location	Page 5
Mounting	Page 5
Wiring connection	Page 6
Installation of the fuel flow transducer	Page 7
Instrument Setup	Page 8
Selecting units of measure	Page 8
Calibration	Page 8
Operation	Page 9
Fuel flow	Page 9
Fuel remaining functions	Page 9
Changing the fuel remaining value	Page 9
Setting the low fuel alarm	Page 10
Alarm activation	Page 10
Resetting the TRIP LOG or the TOTAL LOG	Page 10
Troubleshooting Chart	Page 11

Specifications - for use with gas engines only.

Size

Mount 2 1/16" diameter hole
Depth behind face plate 3" min.
Display 3-character LCD

Backlighting

Red colored diffused lighting for display.

Water Integrity

Front will withstand direct water spray.

Alarm

Audio and visual alarm indicates remaining fuel total has dropped below a preset alarm value.

Flow

0.5 to 34 US gallons per hour
2 to 129 liters per hour
0.4 to 28 imperial gallons per hour
The instrument may show erratic readings or indicate 0 flow below .5 gph.

Logs

Logs record fuel used up to 999 display units.
Both Trip Log and Total Log are saved in memory at power down. Both Trip Log and Total Log can be reset.

Fuel Remaining

User enters a fuel value into memory. The quantity of fuel used is automatically subtracted from the total. This value remains in memory at power down.

Operating Voltage

8 VDC to 16.5 VDC

Operating Temperature

0°C to 50°C (32°F to 122°F)

Current Drain

90 mA max. with supplied transducer.

Compliance/Certifications

<6 dB quieting on any marine radio channel (with 3 dB gain antenna) within one meter of the instrument.
Complies with CE EMC standards EN50081-1 and EN50082-1 and FCC Section 15.
Complies with International Standard ISO 8846:1990(E).

Display is backlit for Night Operation

Change Value Up

Change Value Down

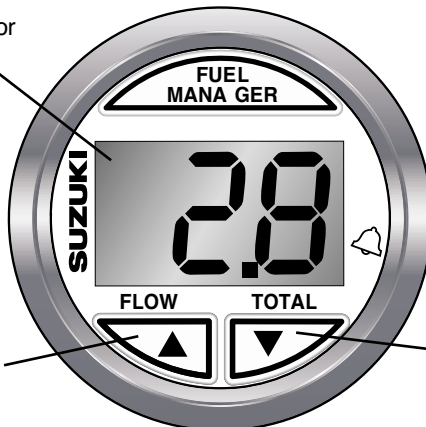

⚠ CAUTION

- Disconnect battery during installation.
- Tighten nuts on backclamp only slightly more than you can tighten with your fingers. Six inch-pounds of torque is sufficient. Over tightening may result in damage to the instrument and may void your warranty.

Installation

Always wire your Fuel Management Gauge into your boats ignition so that when the engine is turned on, the gauge is recording the fuel used. If an accessory switch is used and you forget to turn the unit on then the gauge will not have recorded the fuel used and will be inaccurate. If you are unsure how to do this, contact a qualified marine electrician.

Tools Required

Ref.	Tools Description
1.	3/8" Nut Driver



Location

The Fuel Management Gauge is designed for above or below deck installation. Select a position that is:

- On a flat surface
- At least 12" from a compass
- At least 20" from any radio
- Easy to read by the helmsman and crew
- Protection from physical damage
- Accessible to electrical cable connections.

Mounting

- The instrument panel may be up to $\frac{3}{4}$ " in thickness.
- Drill a $2 \frac{1}{16}$ " hole in the instrument panel.
- Remove brackets and insert the instrument so the back is flush with the instrument panel.
- Slide the back clamp over the instrument and tighten mounting nuts until secure.

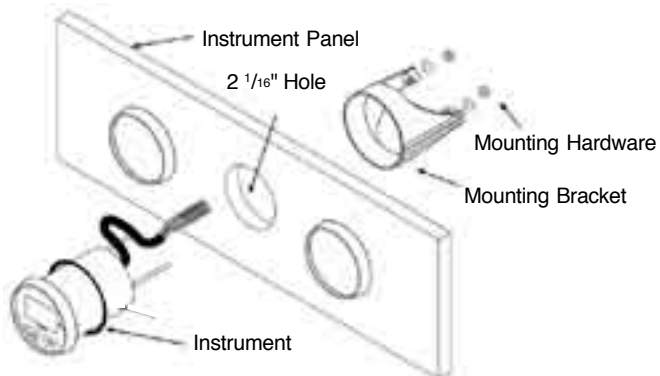

Installation Guide for the fuel flow transducer

CAUTION

A small amount of fuel may be released when the fuel feed hose is disconnected.

Place container under the fuel feed hose or 3-way joint pipe with a shop cloth so that released fuel is caught in container or absorbed in cloth. Place fuel soaked cloth in an approved container.

WARNING

Gasoline is extremely flammable and toxic. Always observe the following precautions when working around gasoline or servicing the fuel system.

- Disconnect battery cables except when battery power is required for servicing/inspection.
- Keep the working area well ventilated and away from open flame (such as gas heater) or sparks.
- Do not smoke or allow anyone else to smoke near the working areas.
Post a "NO SMOKING" sign.
- Keep a fully charged CO2 fire extinguisher readily available for use.
- Always use appropriate safety equipment and wear safety glasses when working around pressurized fuel system.
- To avoid potential fire hazards, do not allow fuel to spill on hot engine parts or on operating electrical components.
- Wipe up fuel spills immediately.

⚠ CAUTION

The fuel flow transducer should not be installed on the engine. Always install the Fuel Flow Transducer AFTER the primary filter. The Primary filter must be a good quality water separator type with a minimum filtration of 30 microns or better.

Damage due to insufficient filtration is not covered by warranty. If in doubt please consult your dealer for advice prior to installation.

Wiring Connection

- Keep electrical and transducer cables away from alternator or other noise generating electrical cables. Avoid connecting the instrument to power circuits that share loads with ignition, alternators, inverters and radio transmitters. Electrical power supply connections should always be as short as possible.
- Connect the gray wire from the gauge to the positive supply through a 1 amp fuse or a 1 amp circuit breaker. Connect the black wire from the gauge to the electrical ground.
- Connect the fuel flow transducer to the gauge as follows:

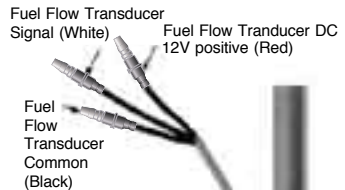
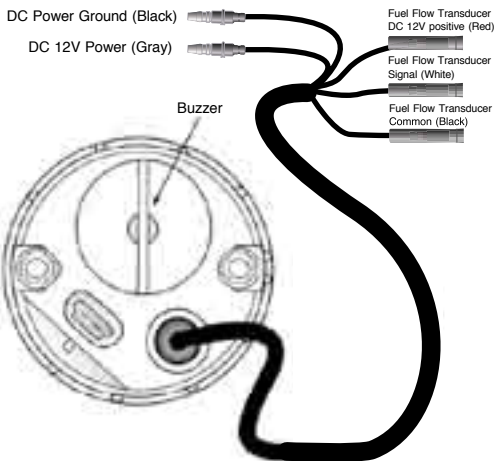

From Tank

Installation of the fuel flow transducer

The fuel flow transducer is designed for installation in Coast Guard approved $\frac{3}{8}$ " flexible fuel line. It should not be installed on the engine. The transducer MUST be installed AFTER the main fuel filter. It should be located well away from any area where it will be effected by excessive heat or vibration from the engine. It is preferable to mount the transducer in a vertical position.

To install, drain all the fuel from the flexible fuel line. Cut the fuel line and, using the fuel hose attaching clips provided, install the transducer so that the **FUEL IN** side of the transducer is connected to the fuel line from the fuel tank .

Instrument Setup

Selecting units of measure

The Fuel Management fuel flow meter will indicate fuel values in US gallons, liters and imperial gallons. To change the current setting perform the following steps.

- 1 Power up the unit while holding down the ▼ key.



Hold down during power up

- 2 When the unit is on, release the ▼ key. The display will indicate the current display unit with:

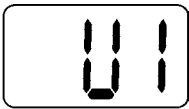

Imperial Gallons



US Gallons



Liters

- 3 To select the display unit desired, use the ▲ and ▼ keys to change the value.
- 4 To exit this mode, press and hold both the ▲ and ▼ keys simultaneously for one second.



Press and hold to exit

Information will now be indicated in the selected display unit.

Calibration

The fuel transducer supplied with the fuel flow meter will provide readings at better than 5% accuracy. Individual calibration will increase this level of accuracy to better than 2% over a fuel flow range of 2 to 32 US gallons per hour.

While a properly calibrated unit should provide accuracy within the published limits, the user should also have a level sender or fuel level gauge installed in the boat. This is necessary due to possible operator induced errors such as forgetting to reset the fuel used when filling the tank, or other operator controlled actions that may render the device inaccurate.

Use the following steps to calibrate your fuel flow meter:

- 1 Reset the total log value to zero (see page 9).
- 2 Use a known amount of fuel. The larger the amount the more accurate the calibration will be.
- 3 Take note of the actual volume of fuel used and the fuel used indicated by the total log. If these two totals are different the instrument may require calibration.
- 4 Press and hold the ▲ key while applying power



Hold down during power up

- 5 Release the ▲ key. The display will flash current total log value.



- 6 Use the ▲ or ▼ keys to make the display indicate the actual volume of fuel used.
- 7 Press both keys simultaneously for 1 second to exit.



Press and hold for 1 second

The fuel flow meter is now calibrated.

Operation

Fuel Flow

Press the ▲ key to display the current fuel flow rate

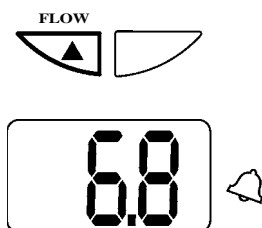

Fuel Remaining Functions

Press the ▼ key to cycle through the possible functions. Each time the ▼ key is pressed the display will show an identifier for 2 seconds before the value is displayed.

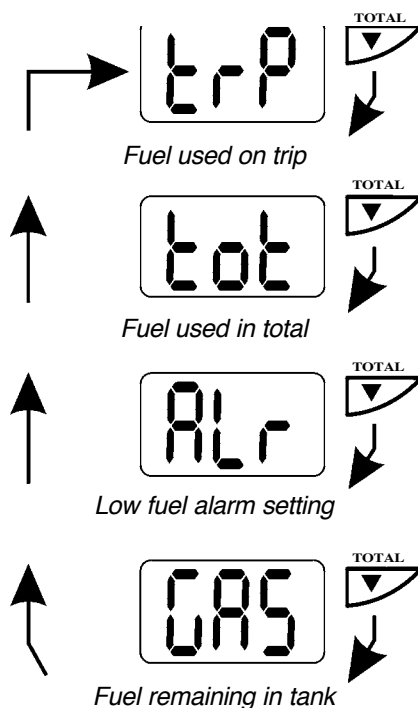

Changing the fuel remaining value

To change the value of fuel remaining in the tank press the ▼ key until the display indicates GAS for two seconds and then displays the current value.



Press and hold both keys for three seconds and the displayed value will begin to flash.

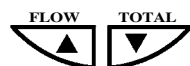

Press and hold for 3 seconds



Use the ▲ and ▼ keys to change the value. Press and hold both keys for one second to save this new value to memory and to exit this function. The display will indicate GAS and then the new value.

Setting the low fuel alarm

Use the ▼ key to select the alarm function. The LCD will indicate **ALr** for two seconds and will then display the present alarm value. If no alarm value has been entered the LCD will indicate **OFF**.

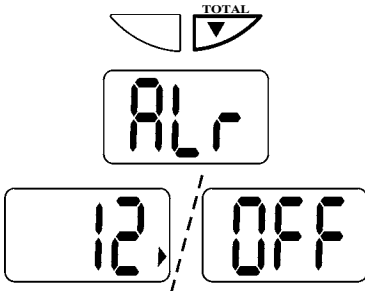

Press and hold both keys for three seconds and the displayed value will begin to flash.

Press and hold for 3 seconds

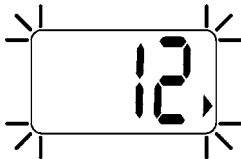

Use the ▲ and ▼ keys to select the desired alarm value. Press and hold both keys for one second to save this new value to memory and to exit this function. The display will indicate **ALr** and then the new value.

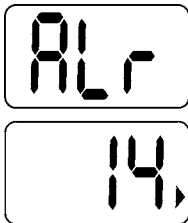

The arrow pointing at the alarm bell will be activated.

Alarm activation

If the fuel remaining value drops below the fuel alarm value, the alarm will sound and the alarm arrow will flash.



Press any key to mute the alarm. The alarm arrow will continue to flash as long as the alarm condition remains.

Resetting the TRIP LOG or the TOTAL LOG

To reset a log, press the ▼ key until the display indicates the name of the log to be reset.

Press and hold both keys for three seconds. The display will show **TRP** or **TOT** for 2 seconds before resetting to zero.

Press and hold for 3 seconds

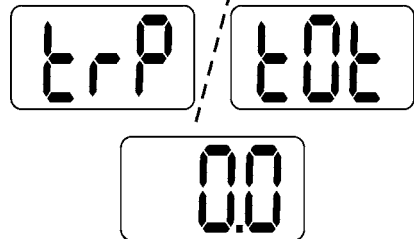

The trip log value may be reset without changing the total log value. If the total log is reset to zero, then the trip log will automatically reset to zero.

Note: If the total log exceeds 999 then both it and the trip log will be reset to zero.

Trouble Shooting

No display:

- 1 Check DC power connections and DC polarity with voltmeter.
- 2 Check fuse.

No flow reading indicated:

- 1 Check connection to flow transducer.
- 2 Remove transducer from fuel line. Blow through transducer. A whistling noise will indicate the turbine is rotating.

Low flow reading indicated:

- 1 Check your primary and secondary filters for obstructions. If no filters are fitted this will lead to blockage and damage of flow transducer (see page 5).
- 2 Check calibration is correct.

No fuel reading:

- 1 Check your primary and secondary filters for obstructions. If no filters are fitted this will lead to blockage and damage of flow transducer (see page 5).

High or erratic reading:

- 1 Check fuel connections are well made. Air in fuel lines will cause erratic or high readings.

Copyright 2004 by the Thomas G. Faria Corporation, Uncasville CT
No part of this publication may be reproduced in any form, in an electronic retrieval system or otherwise, without the prior written permission of the company.
Suzuki® is the trademark of the Suzuki Motor Corporation.