

# Installation Instructions

## Inboard / Outboard Motor

### Tach & Tach/Hourmeter

**CAUTION:** Disconnect the battery during installation. Tighten nuts on the backclamp only slightly more than you can tighten with your fingers. Six inch-pounds of torque is sufficient. Overtightening may result in damage to the instrument and may void your warranty.

1. Location: The tachometer should be located at least 18" from a magnetic compass. Some interference (erratic operation) may be noticed on the tachometer during radio transmissions. This will neither damage a Faria® tachometer nor affect accuracy when not transmitting.
2. Be certain to use stranded, insulated wire not lighter than 18AWG that is approved for marine use.
3. Using a small screwdriver, SLIGHTLY depress and turn the selector switch on the back of the tachometer to the correct position to match the number of poles in the alternator of the outboard engine or the number of cylinders on the inboard engine. (see label on the side of the tachometer).  
Depressing the switch too hard may cause damage to the tachometer! Be sure the selector switch has locked into the detent at the correct position by slightly rotating the switch back and forth with the screwdriver.  
If the number of poles is not known, consult the "Outboard Tachometer Application" chart or call Faria® Marine Instruments at (860) 848-9271 with make, model, HP, and year of the motor.
4. Cut a 3-3/8" dia hole in the dash and mount the tachometer with the backclamp supplied. For connectorized cases be sure to cut a .175" wide by .115" deep notch to accept the key on the case. See detail on next page.

(See diagram on the next page for connections)

#### Standard Case

5. Connect a wire to the tach stud marked "BAT" (battery) and secure with a nut and lockwasher. Connect the opposite end to a 12VDC circuit that is activated by the ignition switch. It is recommended that insulated wire terminals, preferably ring type, be used on all connections to the tach, except the light, which requires a 1/4" insulated female blade terminal.
6. For Outboard applications: Connect a wire to the tach stud marked "SIG" (signal) and secure with a nut and lockwasher. Connect the opposite end to a terminal or wire originating from the unrectified side of the alternator. On most late model outboards, a tach hook-up wire can be found at the control box. Tach plug-in harnesses are sometimes available from the engine manufacturer to simplify the hook-up.
7. For Inboard Applications: Connect a wire to the tach stud marked "SIG" (signal) and secure with a nut and lock washer. Connect the opposite end to a terminal or wire providing the Tach signal from inboard. Refer to engine manufacturer's literature for the location of the signal.
8. Connect a wire to the tach stud marked "GND" (ground) and secure with a nut and lockwasher. Connect opposite end to the boat's electrical ground, generally available in several locations at or near the instrument panel.
9. Connect the blade terminal adjacent to the twist-out light assembly to the positive "+" side of the boat's instrument lighting circuit. No separate ground is required for lighting.
10. Reconnect the battery.

#### NOTE:

- a. To change light bulb, twist black socket assembly one-eighth turn counterclockwise until it pops out. Bulb pulls straight out of assembly. It is a GE No. 194 instrument lamp.
- b. If your Tachometer is equipped with an hourmeter, the hourmeter will be energized when the the engine is running.

#### Connectorized Case

5. Insert a wire with appropriate contact to the Tachometer Signal function of the connector. Connect the opposite end to the terminal or wire originating from the unrectified side of the alternator. On most late model outboards, a tachometer hookup wire can be found at the control box. Tachometer plug-in harnesses are sometimes available from the engine manufacturer to simplify the hookup.
6. Insert a wire with the appropriate contact to the '+' (positive) function of the connector. Connect the opposite end to a 12Vdc circuit that is activated by the ignition switch.
7. Insert a wire with appropriate contact to the ground function of the connector. Connect the opposite end to the boat's electrical ground, generally available in several locations at or near the instrument panel.
8. Insert a wire with appropriate contact to the light function of the connector. Connect the opposite end to the positive portion of the lighting circuit. Insert the connector into the back of the case.

#### Deutsch Connector

Hookup	Function
P1.1	'+' Positive
P1.2	Lights
P1.3	Tachometer Signal
P1.4	N/C
P1.5	N/C
P1.6	Ground

Connector	DT06-6S
Contact	1062-16-0122
Wedge Lock	W6S
Plug	114017

#### Packard Connector

Hookup	Function
P1.A	'+' Positive
P1.B	Lights
P1.C	Ground
P1.D	Tachometer Signal

Connector	12162189
Contact	12124075
Plug	12034413

For technical assistance, contact Faria® Marine Instruments Customer Service between 8:30 AM and 5:30 PM Eastern time weekdays at (860) 848-9271 or (800) 473-2742.

# Standard Case Wire connections

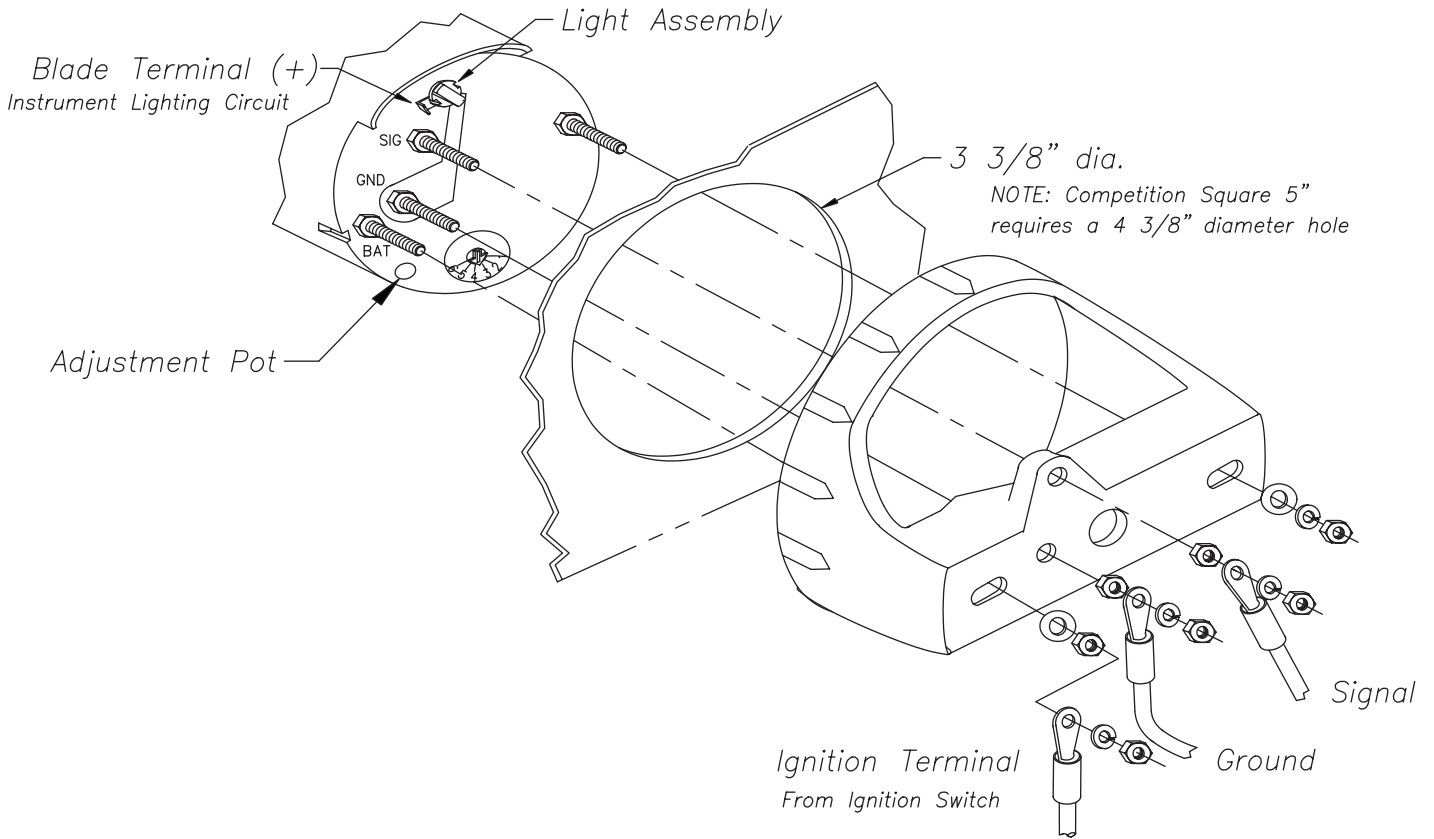

# Connectorized Case Wire connections

Deutsch Connector Case

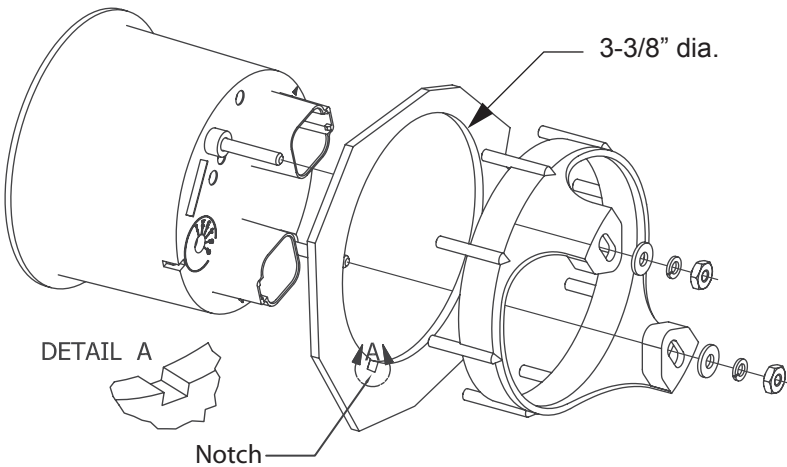

Make / Year	Model	# of Poles	
<b>Chrysler</b> 1968 - 1983	35 HP, 70 HP & up	12	
	55 & 60 HP	20	
<b>Force</b> 1984 - 1999  Some older Force engines are 20 pole (see note d.)	50 HP through early 1987 (A,B models)	8	
	35 HP (1986 & later)	12	
	40 HP (1991 & later)		
	50 HP (1992 B models & later)		
	70 HP (1991 & later)		
	90 - 120 HP L-Drive (1991 B & later)	12	
	145 HP L-Drive (1991 & later)		
<b>Honda</b> Through 2008 Older tiller models require Honda jumper wire 32197-ZH8-003, BF 40/50 HP require 06383-ZV5-316 Tach Kit (thru 2005)	BF 75/100A, BF 8A, BF 9.9/15A HP	4	
	BF 25/30, BF 75/90 HP		
	BF 40/50 (2006 and later)		
	BF 115/130 HP	6	
	BF 135/150 HP, BF 200/225 HP		
	BF 35/45, BF 40/50 HP (thru 2005)	12	
	BF 8D/9.9D, BF 15D/ 20D (Includes Power Thrust Models)	12	
<b>Mercury/Mariner</b> 1977 - 2008 (See note "c") *Use Tach adapter #17461A9 Service #17461T9 **Use Tach adapter MM #17461A8 or A10 Service #56-883040A1  SmartCraft requires AGI converter for Analog Gauges.	18,25,48,60HP Mariner through 1983	4	
	8, 9.9, 15 and 25 HP (4 stroke)(after 1998-2004)		
	Less than 40 HP - All Before 1999	6	
	40 HP(serial # 582399 and before)		
	8, 9.9(Before 1999 and after 2005)& 50HP(4 stroke)		
		6 to 25 HP 1999 & up, *2002 & up	10
		25 HP & 30 HP (4 stroke)	12
	40 HP (after serial # 582399)		
	45 HP (1987), 50-60 HP (4 stroke EFI)		
	50 HP & above, ** 75, 90,115 HP (4 stroke EFI)		
	135, 150, 200, 225 HP, DI	12	
	3.0L EFI 225 & 250 HP		
	Pro Max 3.0L 300 HP EFI		
<b>Evinrude/Johnson</b> 1977 - 2008 for 88 HP {90} & 112 HP {115} a voltage reg. kit is recommended. A System Check Tach or 2" gauge is required	9.9 HP -15 HP 4 stroke after 2001	6	
	All 2 cylinders less than 70 HP	10	
	9.9 HP & 15 HP (2 cylinder)(4 stroke)	12	
	25-35 HP 3 CYL		
	40-50 HP, 2 cylinder (1993 & later)		
	60 HP, 3 cylinder (1985 & later)		
	70 HP & greater, including sea drives	12	
	All FICHT models		
	All E-Tech 40 HP - 250 HP		
<b>Suzuki</b> through 2008 A System Monitor Tach or 2" gauge is required	Less than 55 HP - All	4	
	60 HP, 65 HP thru 1985		
	50 - 60 HP Cabrea	6	
	DF 4 through 30 (4 stroke)		
	25 HP & 30 HP (1993 & later)		
		55 HP & 65 HP (1985 & later)	12
	75 HP & up (1985 & later)		
	75 HP and up (Cabrea)		
	115 HP and up (1988 & later)		
	DF 40 through DF 250, DFV6 (4 stroke)		
<b>Tohatsu / Nissan</b> through 2008 (See note "c").	(2 strokes) 8 HP, 9.8, 9.9, 15, 18, 25, 30, 40C (all 2 cylinder)	4	
	All TLDI 40 through 115		
	(2 strokes) M40D,40D2, 50D, 50D2, 70B and C, 90A (all 3 cylinder)	6	
	(2 strokes) 115 HP, 120 HP, 140 HP (all 4 cyl.) (4 strokes) 8, 9.8, 9.9, 15, 18, 25 & 30 HP, EFI 25, 30	12	
<b>Yamaha</b> 1984 - 2008  V8 four stroke will not support a conventional tachometer.	6 HP - 25 HP (2 cyl '84-'87), F/T 9.9 ('85-'91)	4	
	C25 - C55 (2 cyl) Except C30 (2cyl '93-'97)		
	F/T 9.9 (MID '92 on), C30-C70 (3 cyl)	6	
	C30 (2 cyl '93-'97), 25 HP (3 cyl),		
	25 HP (2 cyl, '88-'05)		
	C/P/E 30-70, F15, F20		
	F/T 25-F250, HPDI 150-300, 80-SX250	12	
	F/T 9.9 (early '92), C75-C150, P75-P200		
	V/VX 150-250, F15C/F20		

Notes:

a. Electrical pulses per revolution are equal to 1/2 the number of alternator poles.

b. Older model outboards (prior to 1977) may have the tach signal wire originating at the ignition system though they are alternator equipped. All alternator tachometers may be used on these systems by disconnecting the tach signal wire at the engine and connecting that wire to the unrectified alternator signal at the rectifier. Be certain the number of alternator poles match the tachometer pole setting of the tach.

c. TOHATSU recommends, when using aftermarket tachs on TLDI engines, using inductor light kit part number 3Y9762510 and Harness 3T5710420. Strong alternator interference on some TOHATSU / NISSAN outboards and some pre 2001 Mercury 90HP outboards may require wiring a .1mf, 100 volt non-polarized capacitor between the signal and ground stud terminals.

d. Faria no longer makes a 20 pole tach.

### 7000 RPM Inboard /Outboard Tach

**SWITCH SETTING**

- 1 - 4 POLE / CYL
- 2 - 6 POLE / CYL
- 3 - 8 POLE / CYL
- 4 - 10 POLE
- 5 - 12 POLE

SLIGHTLY DEPRESS WHILE TURNING