

5 Gauge Box Set

IS0342

Rev. B ecr 8832 9/2012

Performance Series

Part Numbers

KTF039

KTF041

KTF040

Made in the USA

Caution

Disconnect the battery during installation. Tighten nuts on the back clamp only slightly more than you can tighten with your fingers. Six inch-pounds of torque are sufficient. Over tightening may result in damage to the instrument and may void your warranty. Use stranded, insulated wire not lighter than 18 AWG.

Be certain wire insulation is not in danger of melting from engine or exhaust heat or interfering with moving mechanical parts.

Parts List

Speedometer

QTY	Description			
1	Speedometer - Programmable	1		
1	Mounting Bracket	2		
1	Hardware			
2	#8 Brass Nut (5/16")	3		
2	#8 Brass Flat Washer	4		
2	#8 Split Washer	5		
1	HN0733 - Wiring Harness	6		

Fuel Level Gauge

QTY	Description			
1	Fuel Level Gauge	1		
1	Mounting Bracket	2		
1	Hardware			
7	#8 Brass Nut (5/16")	3		
2	#8 Brass Flat Washer	4		
4	#8 Split Washer	5		

Voltmeter

QTY	Description			
1	Voltmeter	1		
1	Mounting Bracket	2		
1	Hardware			
4	#8 Brass Nut (5/16")	3		
2	#8 Brass Flat Washer	4		
2	#8 Split Washer	5		

Water Temperature Gauge

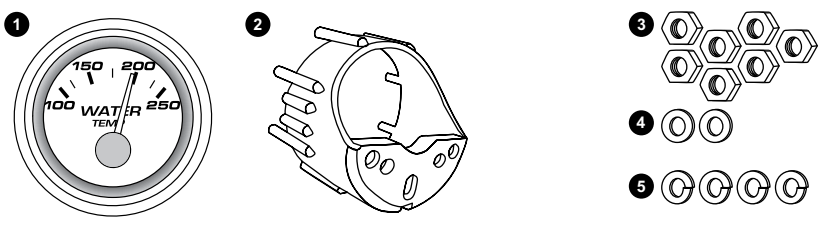
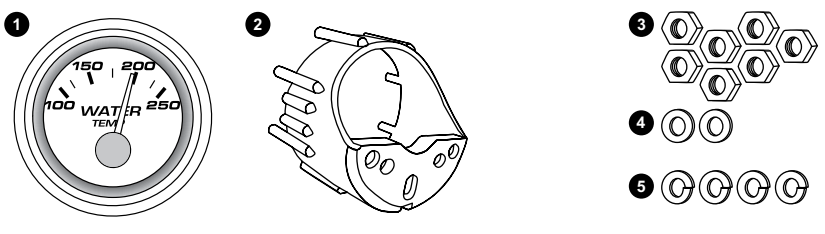
QTY	Description				
1	Water Temperature Gauge	1			
1	Mounting Bracket	2			
1	Hardware				
7	#8 Brass Nut (5/16")	3			
2	#8 Brass Flat Washer	4			
4	#8 Split Washer	5			

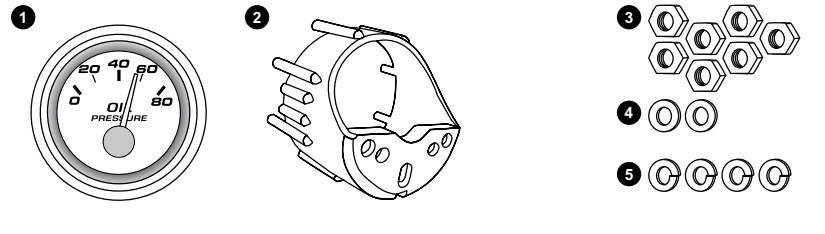
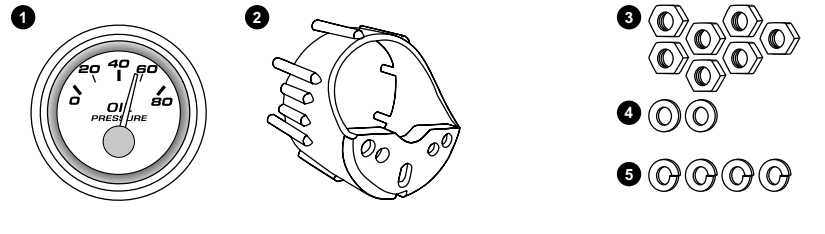

Oil Pressure Gauge

QTY	Description				
1	Oil Pressure Gauge	1			
1	Mounting Bracket	2			
1	Hardware				
7	#8 Brass Nut (5/16")	3			
2	#8 Brass Flat Washer	4			
4	#8 Split Washer	5			

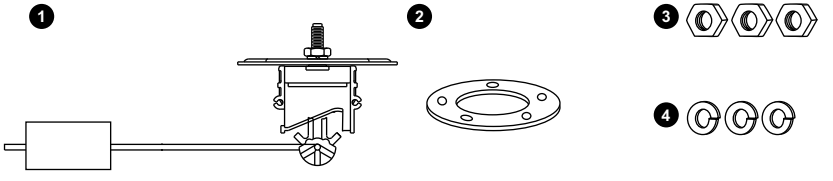
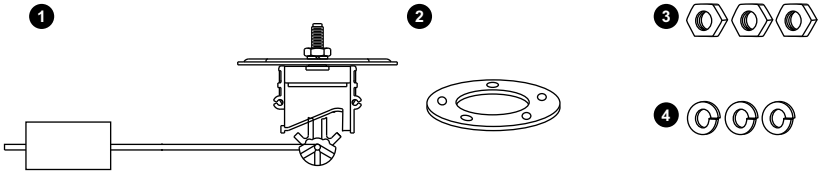
Fuel Level Sender

QTY	Description				
1	LS1038 - Standard 240-33 Ohms	1			
1	Hardware				
1	GK0093 - Gasket	2			
3	#8 Brass Nut (5/16")	3			
3	#8 Split Washer	4			

Pressure Sender

QTY	Description				
1	SD0006 - Pressure Sender	1			
1	Brass Nut (3/8")	2			
1	Brass Flat Washer	3			

Temperature Sender

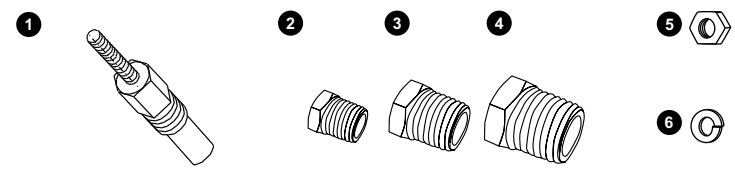
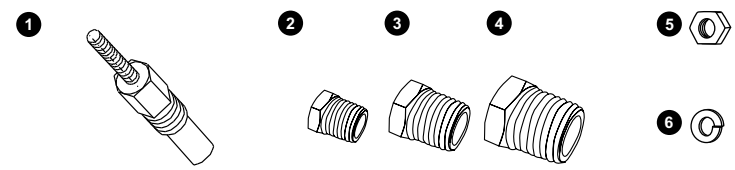
QTY	Description							
1	TS1029 - Temp Sender	1						
1	BS0005 - 1/2 to 1/8 NPTF	2						
1	AD0048 - 1/8 to 1/4 NPTF	3						
1	BS0003 - 1/8 to 3/8 NPTF	4						
1	Hardware							
1	#10 Brass Nut (3/8")	5						
1	#10 Split Washer	6						

Light Bulb Replacement

Fuel Level Gauge	GE No. 658
Voltmeter	GE No. 658
Water Temperature Gauge	GE No. 658
Oil Pressure Gauge	GE No. 658

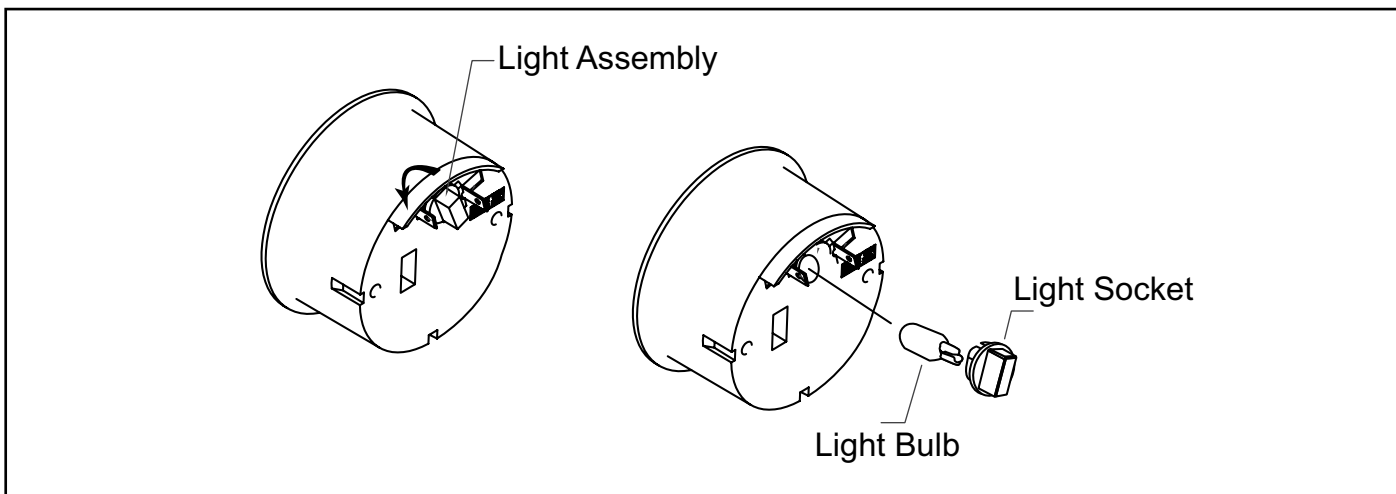

Installation

- 1 Disconnect the negative battery terminal.
- 2 If you are not replacing an existing gauge in the dash, locate a mounting location for the gauge(s) that provide easy readability from the operator's position. Verify there is enough workable space behind the mounting location to install your gauge and make connections if necessary.
- 3 Cut a hole in the dash for each gauge. Use the chart to determine the correct hole size.
- 4 Install the gauge in the mounting hole and check fit.
- 5 Mount the gauge(s) with the mounting brackets using the split washers and brass nuts as shown on the next page. Tighten the nuts finger tight using only 6 inch pounds of torque.

Gauge	Hole Size
Speedometer	85 mm (3.375 in)
Fuel Level	53 mm (2.063 in)
Voltmeter	53 mm (2.063 in)
Water Temperature	53 mm (2.063 in)
Oil Pressure	53 mm (2.063 in)

Warning

Do not over tighten the mounting nuts. Over tightening the nuts may crack the gauge housing, mounting bracket or mounting panel.

- 6 It is recommended that insulated wire terminals, preferably ring type be used on all connections. Light assembly connections require 6 mm (.25 in) female blade terminal.

Voltmeter Connections

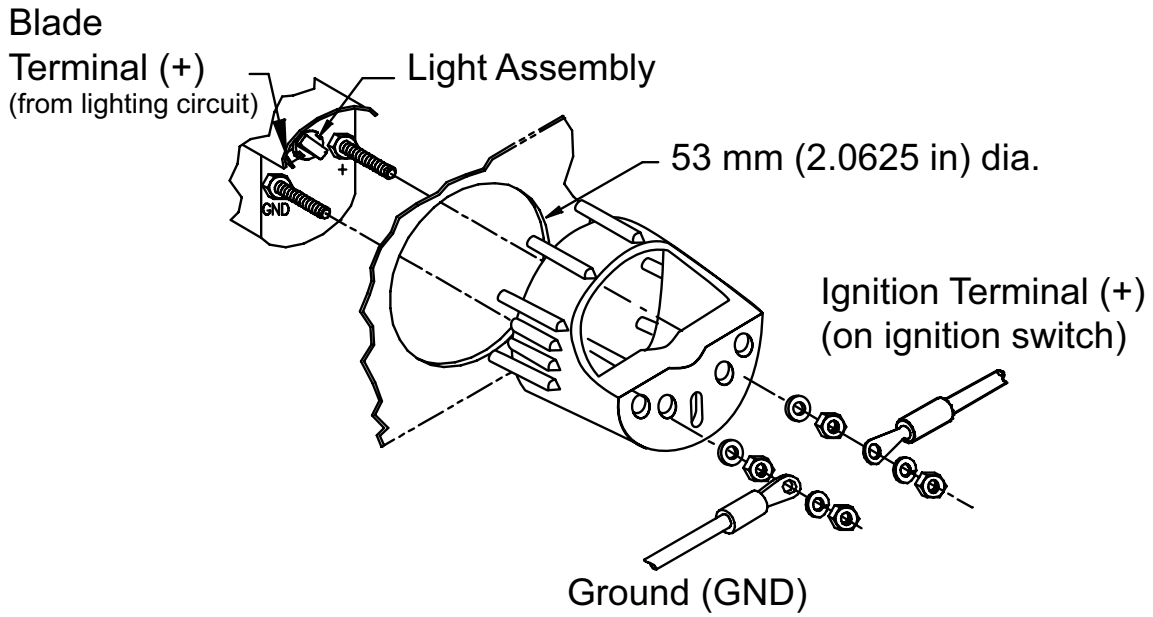

Fuel Level Gauge Connections

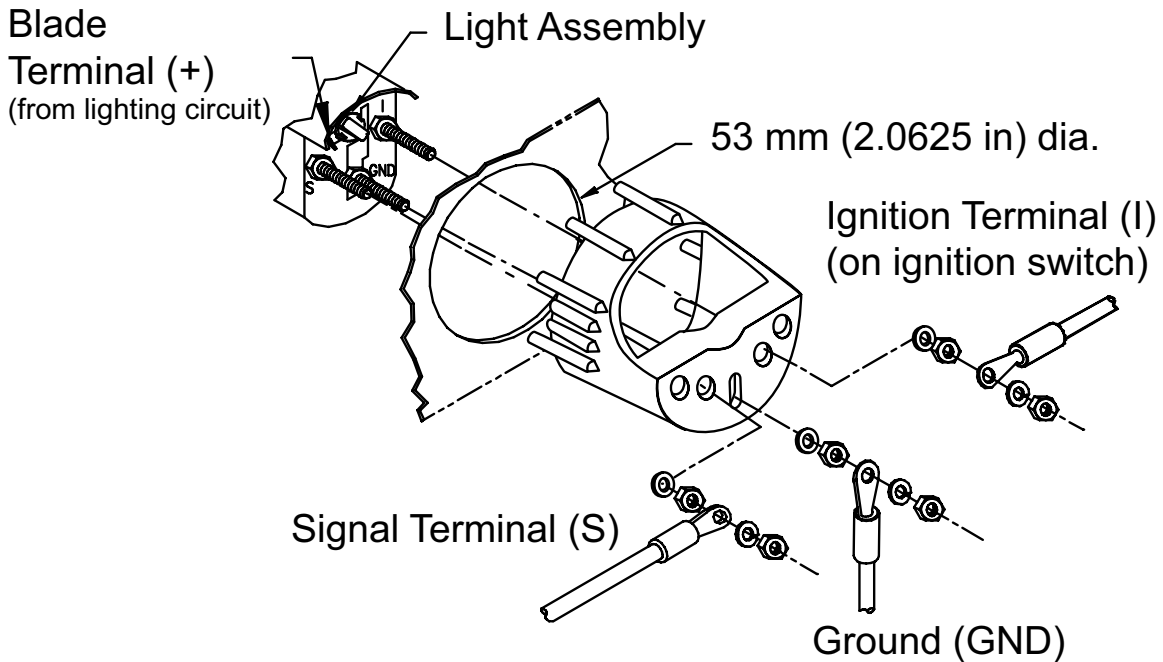

Special Caution should be taken when working on or around tanks that have, or have had fuel in them.

Water Temperature Gauge Connections

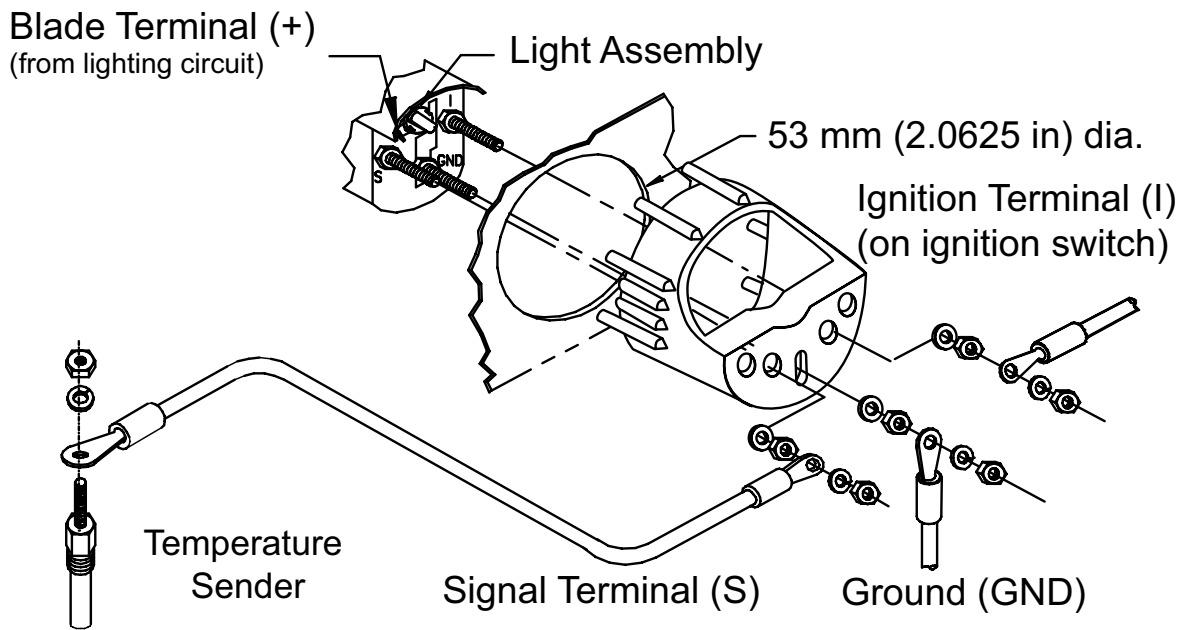

Oil Pressure Gauge Connections

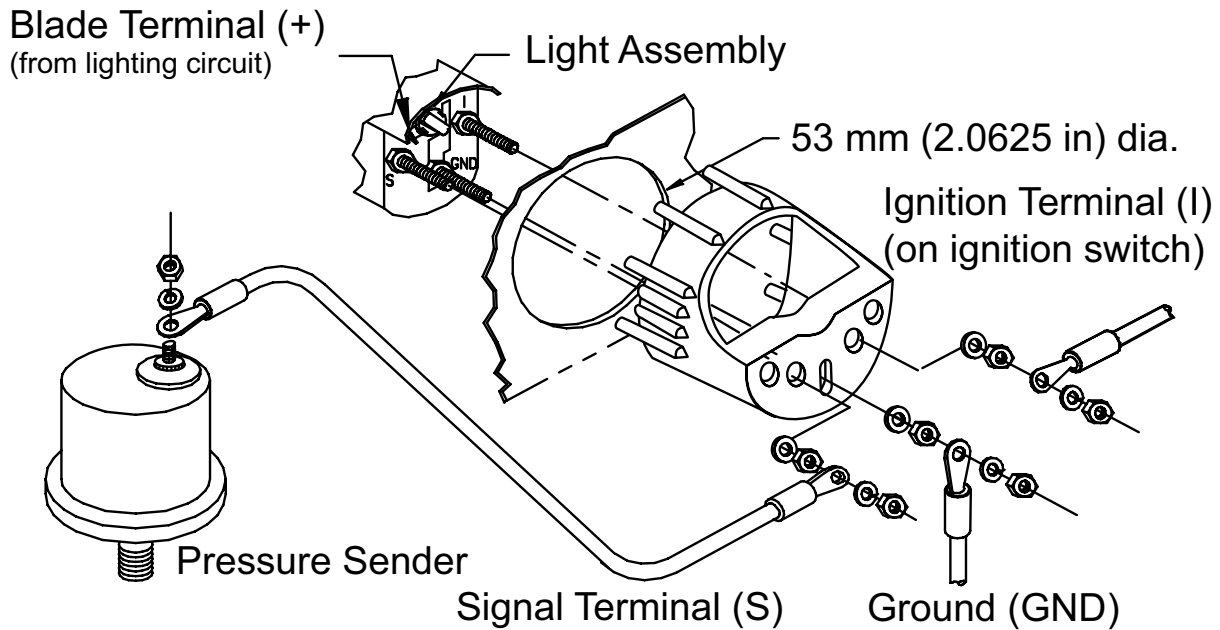

Electronic Programmable Speedometer

Speedometer Connections

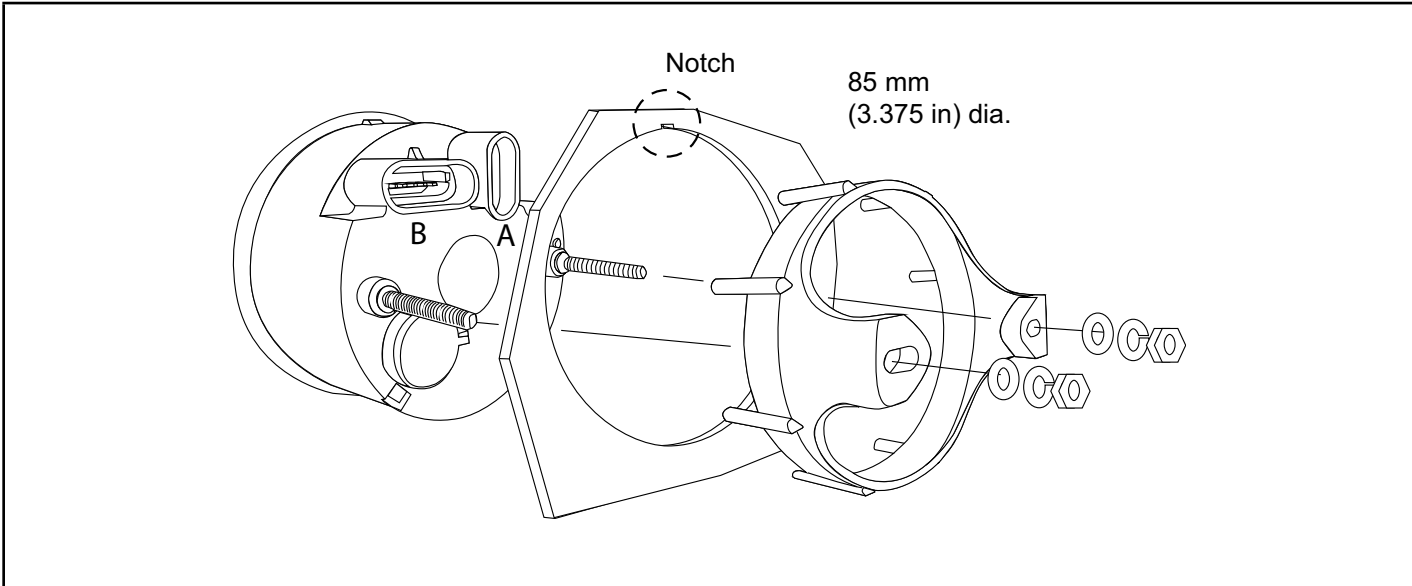

HN0733 - Wiring Diagram

B - Connections

Pin A	Battery Input
Pin B	Ground
Pin C	Over speed signal
Pin D	External Push-Button grnd
Pin E	Hourmeter control
Pin F	Speed Axle

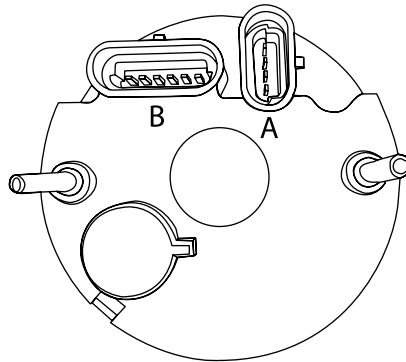

A - Connections

Pin A	Sensor V Out
Pin B	Sensor Signal Input
Pin C	Ground
Pin D	Back/Dash Lights



- 2 speed axle (ground selects low axle, open connection selects high axle)
- Hourmeter control (ground disables hour-meter)
- External push button (ground active)
- Over speed output (ground when over set speed, 20 milliamps max current)
- Ground
- Battery input



- Dash lights (controls gauge back lights)
- Ground
- Speed pulses in from sensor
- Power for external sensor

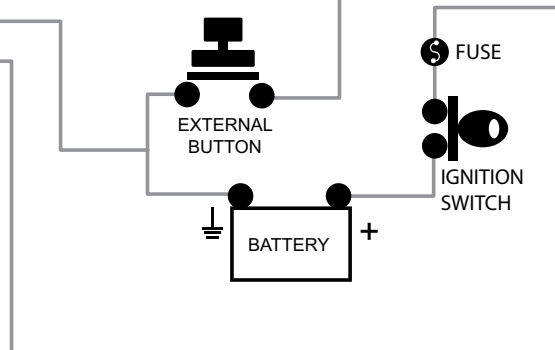

Speedometer Operations

Functions available:

1. Odometer display
2. Trip odometer display (resetable)
3. Hour-meter (either rpm or key-on)
4. Service interval for miles or kilometers (reset, clear and disable features)
5. Service interval for hours (reset, clear and disable features)
6. Over-speed indicator (microprocessor output level change at over-speed, resetable)
7. Two speed axle, selected by input to microprocessor.
8. Pulses per mile or kilometer input or change.
 - A. PPM can be done automatically by the microprocessor.
 - B. PPM numbers can be entered using the push-button.
 - C. All features available for both high and low speed axles.
9. Display the highest speed recorded by the microprocessor (resetable). The hour-meter and the odometer reading at the maximum speed time are also recorded. This information is not available for display or resetting.

The speedometer must be returned to the factory for reading.

Detail description

Odometer

The commercial speedometer contains an odometer to maintain a record of the total mileage and trip mileage. During normal operations and after a power on the odometer display shows;



This display cannot be reset. A quick press of the push-button changes the display to the Trip odometer.



Trip Odometer

The Trip odometer allows you to keep a record of the trip miles or kilometers independent of the Odometer.



The Trip Odometer is fully user resetable. While in the Trip Odometer display press the push-button for 4 seconds and the Trip odometer is reset to zero.



The pointer travels over a 270-degree dial to indicate mph (or kph) indicates the speed. The kph is handled the same as a mph in the microprocessor. The pulses per mile will be pulses per kilometer and the self-cal will be for 1 kilometer instead of 1 mile. There is no provision to change from miles to kilometers.

Hour-meter

The speedometer also contains an hour-meter that is always activated by an external input so that actual engine hours can be recorded. Quick press the push-button while in the Trip Odometer function displays the Hour-meter.



The last digit on the right blinks up and down indicating the hour-meter function. The hour-meter cannot be reset.

Grounding P1-E thru an oil low pressure switch can stop the hour-meter. If P1-E is not grounded then the hour-meter will run continuously with the key on. To provide a true engine running hour-meter an external low oil pressure switch is normally used. The low oil pressure switch is normally used. The low oil pressure switch is closed connecting the pin to ground. The hour meter is not running. When the engine is running the normal high oil pressure opens the low oil pressure switch allowing the hour-meter to operate.

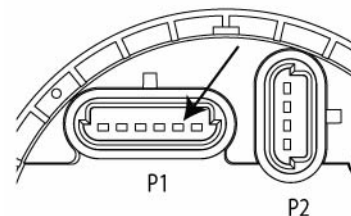

Over Speed Condition

An over-speed condition will ground P1-C (maximum 40 milliamp load) on the speedometer when a pre-set speed has been passed. This output can be utilized by the customer to activate a warning device.

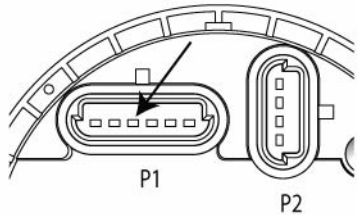

Maximum Saved Speed

This speedometer will also record the maximum speed under normal conditions. The maximum speed is displayed and changes as the speed is increased over the current maximum.



The maximum speed can be reset by pressing the push-button for 4 seconds.



Another feature of the speedometer is to keep track of and indicate when a service interval has passed. The interval can be either or both mileage and hours.

A seven digit display readout displays the total mileage, the trip mileage, hour-meter or maximum saved speed (cleared by pressing and holding the push-button for 4 seconds while in the maximum speed display), the menu items are scrolled by pressing and releasing the push-button on the speedometer.



If a service interval has been passed the display will show a service message (one time only).

Service Hours



Service Distance



Pressing the push-button will return the display to the primary mileage and hour displays.

The service interval message will also show once every time the speedometer is powered up. The display can be cleared by the push-button. The pulses per mile output from the sensor to the speedometer can be programmed by hand or done automatically, for both of the high and low range axles.

Setting the speedometer

There are two major speedometer setting routines.

The first is activated during boot-up. If the push-button is pressed and held on when power is first turned on the "boot menu" will be activated.



The second menu, the "run menu", can be activated during normal running time by pressing and holding the push-button for two seconds.

Boot menu

Pressing and holding the push-button while power is turned on will activate the "boot menu".



The display will show "HELLO" and wait for you to release the push-button.



When the push-button is released the first item on the menu will be shown. In four seconds the microprocessor will activate that menu feature.

If you want a different item from the menu, you must press and release the push-button before four seconds have elapsed. The menu items will scroll continuously. If you want to get out at this point with no changes, stop at the last menu item "donE", and in four seconds the microprocessor will return to normal with nothing being changed.



If you are in a menu, just do nothing for 32 seconds and the microprocessor will restart and change nothing.

1. The first menu item "SEr HrS" (Service Hours) is used to set the next service interval in hours.

When this menu feature is started, the display will show the actual hours when the present hour service interval will occur.

The main purpose of this menu feature is to set the next hour service interval time, however it can also be used to check when the present service interval will occur. Starting at the left most digit, the digits will flash on and off for four seconds.

During this time you may change the digit by pressing and releasing the push-button.



Once you have changed the digit once you may push and hold the push-button to have that digit count continuously from 0 to 9. When you have made your digit choice, don't touch the push-button for four seconds and the next digit to the right will now flash and be accessible for change.

This will continue for all the digits and will go back to the first digit and repeat. If the push-button is not pressed for 32 seconds the microprocessor will return to normal and will change nothing.

This is useful if you're only here to check when the present service interval will occur. The operator may also turn power off at this point and nothing will change in the microprocessor controller.

To save the changes you have made in the display, you must press and hold the push-button while any digit is flashing.



The digit will stop flashing and four seconds later the microprocessor will reset any previous events pertaining

to the hour service interval, and install the new numbers. When the microprocessor is finished the display will change to "donE".

The trip switch must now be released to return to normal operation. If the present hour-meter is close to 999,999, your new number may be past the overflow so when you examine when the hour service event will occur, the number shown will be less than the current hour-meter. This is because the current hour-meter must overflow and start at zero before the service event can occur.

2. The second menu item "Ser diS" (Service distance) will allow you to program the mileage service interval.

The description and operation are the same as number 1 above except the mileage service interval is changed or observed.

3. The third menu item "Clr HrS" (Clear Hour Service) allows you to clear the hour service flag and automatically reset the next hour service.

The calculation will use the previous interval value. When the operator stops at the "Clr HrS" display and waits four seconds the service interval will be changed.

4. The fourth menu item "Clr diS" (Clear distance) allows you to reset the mileage service interval.

The implementation is the same as number 3 above.

5. The fifth menu item "PPgn Hi" (Program High axle) will allow the operator to enter the pulses per mile or kilometer for the high axle.

This number will depend on how your particular sender is arranged. The maximum pulses per mile or kilometer are

limited to 150,000. When you stop at the “PPn HI” display and wait four seconds the microprocessor will display six digits with the left most digit flashing.



The number displayed will be the present pulses per mile or kilometer rounded off to the nearest 100 th. The right most digit will be a “P” to remind the operator that they are in the “Programming” mode. The digit changes and inputs are the same as number 1 (Service Hours) above.

Also present is the same option to do nothing for 32 seconds and the microprocessor will reset itself and will change nothing.



Holding the push-button on for four seconds while a digit is flashing will make the microprocessor compute the observation window and will store this window and the pulses per mile or kilometer rounded off to the nearest 100 pulses in the EEPROM. The display will now show “donE” and the operator should release the push-button to resume normal operations.



6. The sixth menu feature “PPgn LO” (Program Low axle) is used to program the low speed axle pulses per mile or kilometer.



This function is not operative.

7. The next item in the menu is the input level control for the speed pulse input. The display will show “ InPuT “.



If nothing is done for 4 seconds then the display will change to “L n H” and the L will be flashing and every 4 seconds the next letter will flash.



If the button is pressed when any selection is flashing, that input signal level will be set to that level.

The choices are low, normal and High. Low is normally used for magnetic pickups and normal and high for other types.

8. The last menu item “donE” is used to exit from this menu.



Leaving the display in “donE” for four seconds will cause the microprocessor to go back to normal operations and change nothing.

Run menu

Pressing and holding the push-button for two seconds during normal operation will activate the “run menu”.



The display will show “HELLO” and wait for you to release the push-button.



When the push-button is released the first item on the menu will be shown. In four seconds the microprocessor will go to the first menu feature.



If you want a different item from the menu, you must press and release the push-button before four seconds have passed.

The menu items will loop continuously. If you want to get out at this point with no changes, stop at the last menu item “donE”,



and in four seconds the microprocessor will return to normal with nothing being changed or if you are in a menu, just do nothing for 32 seconds and the microprocessor will restart and change nothing.

1. The first item in the run menu is “Clr OdO” (Clear trip odometer).

If the operator stops at this display, the microprocessor will reset the trip odometer to zero and will return the microprocessor to its normal operation.

2. The second menu item "SET SPd" (Set Speed) is used to set the speed at which the over-speed indicator will activate.

Not installed.

Stopping at this display and waiting four seconds will set the display to three digits corresponding to the last speed that the over-speed was set to.

The left most digit will be flashing and the change and implementation of the input numbers are the same as above. When the push-button is held for four seconds the microprocessor will set the number in the display to be the new over-speed trip point.



The option to get out with no changes is available by not making any changes for 32 seconds.

3. The third menu feature "SELF HI" (Self calibrate high axle) can be activated by waiting at this display for four seconds.

This is a feature to allow automatic setting of the high axle pulses per mile or kilometer that the speedometer will use to position the pointer and record the correct mileage.

This is accomplished by indicating to the speedometer microprocessor, the beginning and end of a measured mile or kilometer. The microprocessor will actually count the pulses that occurred during that mile or kilometer and compute the required parameters. When this mode is activated the speedometer will display "PEndInG".

This means that the microprocessor is waiting for the push-button to be pressed indicating the beginning of the

measured mile or kilometer.

When the push-button is pressed and released the display will change to "SELF HI" indicating that the microprocessor is now counting pulses.



The speed at this point is not important. The operator may even stop and wait, as long as power is not turned off and the measured mile or kilometer is followed as straight as possible, the operator may not turn around and go in the opposite direction.

Also for the maximum accuracy, the operator should not enter any off road parking as this would deviate from a straight mile or kilometer measurement.

At the end of the measured mile or kilometer the operator must press and release the push-button one more time,



the display will show "CALCInG" (Calculating)

while the microprocessor calculates the numbers it needs and will restart. The new pulses per mile or kilometer will now be in effect. This feature may be abandoned at anytime by pressing and holding the push-button for two seconds. The microprocessor will reset itself and continue normal operations. This menu item may also be stopped by turning off power to the speedometer.

4. The forth menu item "SELF L" (Self calibrate low axle) is used to automatically calculate the pulses per mile or kilometer for the low ratio axle.

Not installed in this application.

The implementation and setting are the same as number 3 "SELF HI" above.

5. The last feature "donE" is used to exit from this menu. If this display is left on for

done

four (4) seconds and the push-button is not pressed, the microprocessor will return to normal operation with nothing changed.

Installing the Fuel Level Sender

Standard Fuel Level Sender 240-33 Ohms

Warning

Read all instructions thoroughly before installation. If you are not experienced in working with fuel tanks, seek professional assistance. Disconnect battery before proceeding! Any type of work involving fuel tank repair or modification should be performed with extreme care. Due to the possibility of igniting fuel fumes, the tank should be empty, dry, and purged of fumes. Work should be performed in a well ventilated area. Only tools that will not create possible fuel ignition sparks should be used. Failure to comply with installation instructions may result in unsatisfactory instrument performance. Improper installation or use of the product for an application other than its intended use will void your warranty and could result in serious personal injury.

Tools You Will Need

Tape Measure
Hacksaw
3/8" Wrench

Part I: Adjusting the Sender

1. Measure the depth of the tank down through the large hole.
2. Allow the Float Arm to hang down loosely so that the float hangs just above the tank bottom. See Illustration A. Measure the length of the Float Arm. If the Float Arm is too long you must cut off the excess with a hacksaw.

Illustration A

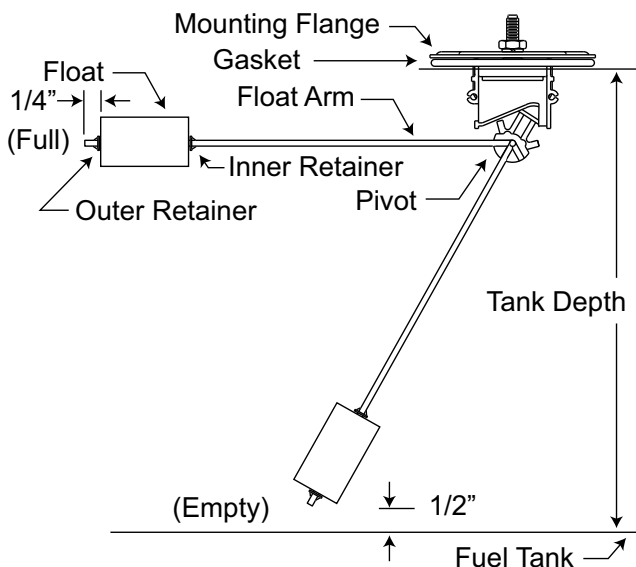

3. Slide the Float and both Retainers toward the Pivot along the Float Arm to the desired length. Leave about 1/4 inch of the arm beyond the Outer Retainer and cut off the excess. Do not position the Inner Retainer at this

time.

4. Insert the Float and Float Arm assembly into the tank hole, and lower the sender until the mounting flange makes contact with the top of the tank. Make sure the flange is positioned flat against the tank. The Float should hang freely and not contact the bottom of the tank. If the float contacts the bottom of the tank, slide the Float and the Retainer 1/4 inch up the arm towards the Pivot and trim the excess as in step 3. Try the fit again, and repeat this step as necessary for the Float to hang freely. Now you may slide the Inner Retainer against the Float.

Part II: Installing the Sender

1. Place the gasket on the tank top and rotate it until all the holes align properly. Lower the float into the tank and lower the sender until the mounting flange is flat on the gasket and all the holes align properly.

Important

Use only the Faria gasket supplied with the level sender. The use of any other gasket could effect the function of the sender, result in damage to the sender or may not provide a reliable seal between the tank and sender.

NOTE: If you find that when aligning the holes, the float arm hits the tank side, a baffle, or a pick-up tube, it will be necessary to rotate the float arm. (In most applications the float arm should point forward).

2. Gently turn all the screws or nuts until they just contact the mounting flange. Snug the screws or nuts in opposite sequence. If you do this in several stages it will ensure that the mounting flange evenly compresses the gasket. Do not overtighten as you may strip out threads in tank top.

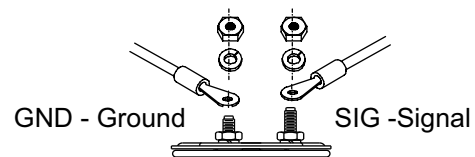

3. Connect the end of the black ground wire to ground (GND). Connect the signal wire (SIG) to the signal wire of the gauge. Your installation is now complete.

Caution

Observe the fuel tank during initial operation to be sure there are no leaks!

Oil Pressure Senders

Engines or transmissions equipped with a low oil pressure switch that activates a warning light require an appropriate "T" pipe fitting to accommodate both pressure sender and warning light. Most oil pressure sending units have 1/8" NPT pipe threads and are usually mounted in the engine's block. If the block or transmission case has a larger pipe size, an appropriate bushing may be used without affecting pressure- sensing accuracy.

Temperature Senders

Temperature senders are available from Faria® Performance Instruments in 1/8" NPT thread sizes. If your water jacket, oil pan or transmission housing requires a thread diameter larger than 1/8" NPT, a bushing will be required. "T" fittings should NOT be used as these may affect the accuracy of the sender by reducing the temperature signal.

Sender Specifications

Temperature Sender:	100°F (450 Ω) to 250°F (29.6 Ω)
Fuel Level Sender:	E(240 Ω) - F (33.5 Ω)
Oil Pressure:	0 PSI (240 Ω) - 80 PSI (33.5 Ω)

SD0047 (Faria part#) may be used for Speedometer sensor.
Mount to bell housing to count flywheel teeth.

DK9005 (Faria part#) Hooks up to mechanical take off on transmission.

