



Tachometer with Hourmeter - Trim Kit

Operations Manual

Caution

Disconnect the battery during installation. Tighten nuts on the back clamp only slightly more than you can tighten with your fingers. *Six inch-pounds of torque are sufficient.* Over tightening may result in damage to the instrument and may void your warranty. Gasket cement or other adhesive is not required to secure tubing to fittings.

Use stranded, insulated wire not lighter than 18 AWG approved for marine use.

Be certain wire insulation is not in danger of melting from engine or exhaust heat or interfering with moving mechanical parts.

Parts List

Tachometer (3PU-72637-0 / 3PV-72637-0)

| QTY | Description | | | | |
|----------|-----------------------|---|--|--|--|
| 1 | Tachometer | 1 | | | |
| 1 | Mounting Bracket | 2 | | | |
| Hardware | | | | | |
| 7 | #10-32 Brass Nut | 3 | | | |
| 2 | #10 Brass Flat Washer | 4 | | | |
| 4 | #10 Split Washer | 5 | | | |

Trim Gauge (3PU-72571-1 / 3PV-72571-1)

| QTY | Description | | | | |
|----------|----------------------|---|--|--|--|
| 1 | Trim gauge - TOHATSU | 1 | | | |
| 1 | Mounting Bracket | 2 | | | |
| Hardware | | | | | |
| 7 | #8-32 Brass Nut | 3 | | | |
| 2 | #8 Brass Flat Washer | 4 | | | |
| 2 | #8 Split Washer | 5 | | | |

Installation

1. Disconnect the negative battery terminal.
2. If you are not replacing an existing gauge in the dash, locate a mounting location for the gauge(s) that provide easy readability from the operator's position. Verify there is enough workable space behind the mounting location to install your gauge and make connections if necessary.
3. Cut a hole in the dash for each gauge. Use the chart to determine the correct hole size. Install the gauge in the mounting hole and check fit.
4. Mount the gauge(s) with the mounting brackets using the split washers and brass nuts as shown on the next page. Tighten the nuts finger tight using only 6 inch pounds of torque.

Warning:

Do not over tighten the mounting nuts. Over tightening the nuts may crack the gauge housing, mounting bracket or mounting panel.

5. It is recommended that insulated wire terminals, preferably ring type be used on all connections. Light assembly connections require 6 mm (.25 in) female blade terminal. Make all connections using the instructions on the next page.
6. After all connections are made reconnect battery.

| Gauge | Hole Dia. |
|------------|------------------|
| Tachometer | 85 mm (3.375 in) |
| Trim Gauge | 53 mm (2.063 in) |

Light Bulb Replacements

| | |
|------------|------------|
| Tachometer | GE No. 194 |
| Trim Gauge | GE No. 161 |

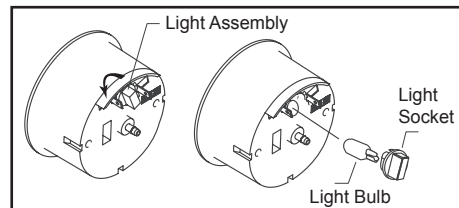

NOTE: To change light bulb, twist black socket assembly one-eighth turn counter clockwise until it pops out. Bulb pulls out of socket assembly.

Tachometer Wiring

- Using a small screwdriver, SLIGHTLY depress and turn the selector switch on the back of the tachometer to the correct position to match the number of poles in the alternator (see label on the side of the tachometer).

Depressing the switch too hard may cause damage to the tachometer! Be sure the selector switch has locked into the detent at the correct position by slightly rotating the switch back and forth with the screwdriver.

- Connect the BLACK/YELLOW wire to the tach stud marked "BAT" (battery) and secure with a nut and lock washer. Connect the opposite end to a 12VDC circuit that is activated by the ignition switch. It is recommended that insulated wire terminals, preferably ring type, be used on all connections to the tach, except the light, which requires a 1/4" insulated female blade terminal.
- Connect the GRAY wire to the tach stud marked "SIG" (signal) and secure with a nut and lock washer. Connect the opposite end to a terminal or wire originating from the unrectified side of the alternator. On most late model outboards, a tach hook-up wire can be found at the control box. Tach plug-in harnesses are sometimes available from the engine manufacturer to simplify the hook-up.
- Connect the BLACK wire to the tach stud marked "GND" (ground) and secure with a nut and lock washer.

Connect opposite end to the boat's electrical ground, generally available in several locations at or near the instrument panel.

- Connect the blade terminal adjacent to the twist-out light assembly to the positive "+" side of the boat's instrument lighting circuit the RED/WHITE wire. No separate ground is required for lighting.

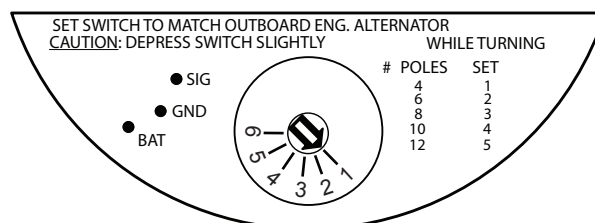

Outboard Tachometer Application Chart

| Model | Pole | Pulse | Setting |
|------------|------|-------|---------|
| BFT60 | | | |
| BFT75/90 | | | |
| BFT115/150 | 4 | 2 | 1 |
| BFT200/225 | | | |
| BFT250 | | | |

Diagram

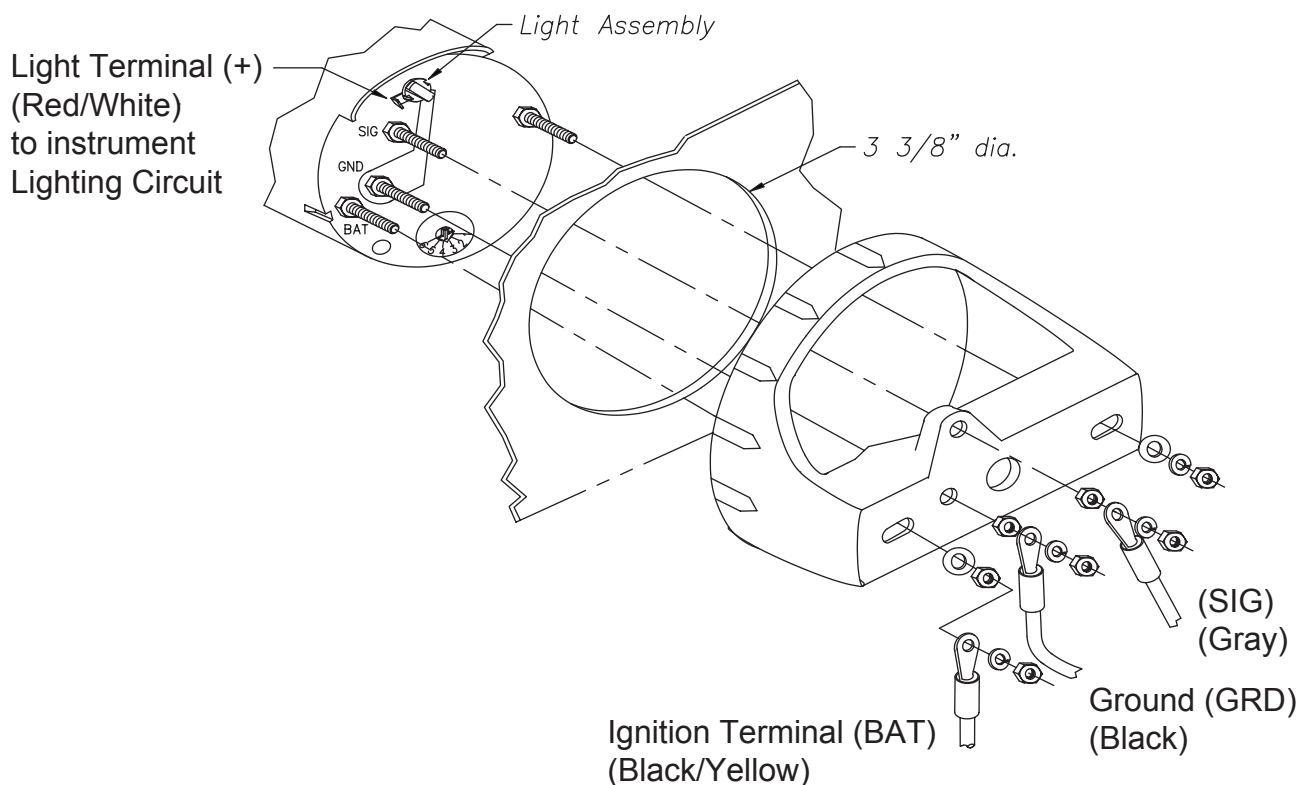

Trim Wiring

1. Connect the YELLOW/BLUE wire to the stud marked "SIG" (signal) and secure with a nut and lock washer. Connect the other end of the wire to the trim signal terminal or wire. It is recommended that insulated wire terminals, preferably ring type, be used on all connections to the gauge, except the light, which requires a 1/4" female blade terminal.
2. Connect the BLACK wire to the stud marked "GND" (ground) and secure with a nut and lock washer. Connect the other end of the wire to the boat's electrical ground, generally available in several locations at or near the instrument panel.
3. Connect the BLACK/YELLOW wire to stud marked "B+" (ignition) and secure with a nut and lock washer. Connect the opposite end to a 12VDC circuit that is activated by the ignition switch.
4. Connect the RED/WHITE wire to the blade terminal adjacent to the twist-out light assembly to the positive "+" side of the instrument lighting circuit.
5. Connect the BLACK wire to the blade terminal adjacent to the twist-out light assembly to the positive "-" side of the instrument lighting circuit.

Diagram

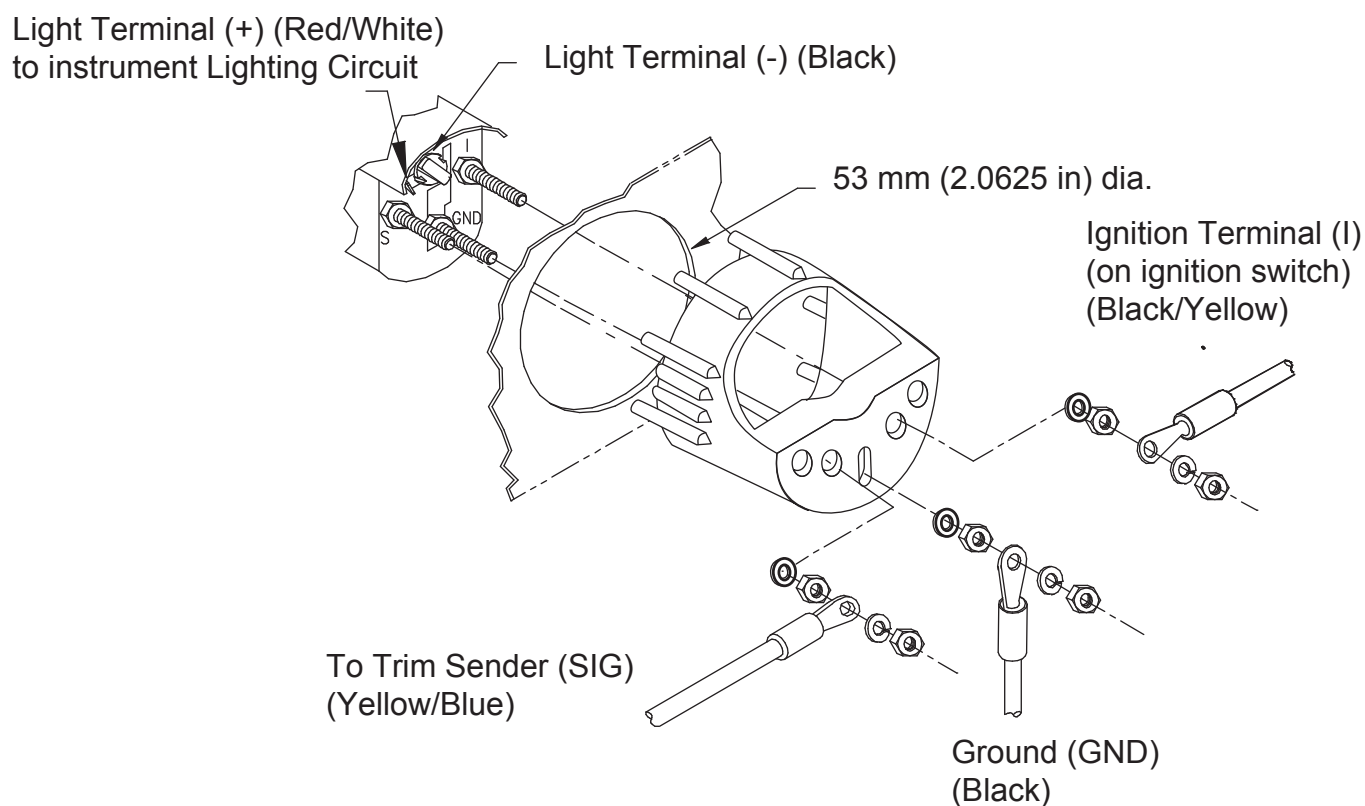

Harness (3PU-73537-0)

