



## Control Panels and Instruments for Electronically Governed Engines



# Universal M150L Series Control Instruments

for Electronically Governed Engines

The M150L Series Control Kits are designed to provide Plug N' Play solutions for installations with existing panel designs and are featured in our L15 and L20 Engine Control panels. These kits are designed to control J1939 electronically governed engines.

With a full featured J1939 interface the L00 series kits provide a complete interface for virtually any SAE J1939 data. With standard features such as "TSC1 Throttle Control", "Fuel Level Input", "Engine Oil Pressure" and "Engine Shutdown", the L00 series kits provide the most features in the price range.

With the traditional look of a round gauge using the latest microprocessor technology the M150L series products provide the user with a traditional "look and feel" for controlling the latest electronic engines. Incorporating the latest technology allows the M150L products to be fully scalable from a single gauge solution to a full feature multi-gauge applications.



## DISPLAY

The 128x64 LCD display provides an easy to read viewing area for system configuration and virtually any data reported by the ECU.



## THROTTLE CONTROL

A single momentary rocker switch adjusts the engine speed via CAN Bus communications to the engine. The throttle functionality is user selectable allowing the rocker switch to provide a smooth ramp function or a fixed rpm 2-State setting.



## ENCLOSURE

The M150L Series Control Panels are built to withstand the harshest environments.

The M150L15 panels are made from 14 gauge cold roll steel with welded seams. All units are powder coated to provide durability under extreme conditions. The L15 series panels provide 4 or 5 inch and 5-2 1/16 inch gauge openings to allow a choice of expansion gauges including traditional switch gauges.

The M150L20 and Pro Series Control Panels are provided in a sealed NEMA 4X housing which terminates to a sealed Deutsch weatherproof connector.

## CONNECTOR

A water tight 21-pin connector is used for plug-in installation.

## CONFIGURABLE ENGINE SPEED LIMITS

The M150L Series Control Kit provides the user with two confirmable engine speed settings. These speed settings can be set to any engine rpm within the min. and max rpm range of the engine. One speed setting for minimum engine speed (i.e. Min RPM) and the other speed setting for maximum engine speed (i.e. engine Max RPM)



## FAULTS

The M150L displays diagnostic messages from the ECU per J1939 format. All DM1 and DM2 diagnostic messages from the Engine ECU are reported. Engine specific diagnostics messages are available for specified engines. (See part number section for list of specific engine types.) Faults are indicated with a Red LCD display backlight. Warnings are indicated with an Amber LCD display backlight.



## ENGINE SHUTDOWN

A contact closure to ground for Engine Shutdown is provided as a customer input. When activated the M150L System will remove ignition voltage to the engine stopping the engine. The system will provide an alarm popup screen to signal the operator that the engine was remotely shutdown.



## FUEL LEVEL

User configurable analog input for fuel level sensors. US 240-33 and Euro 10-180 ohm senders can be selected.

## MAINTENANCE TIMER

User configurable maintenance timer. When programmed system provides warning message when maintenance timer has expired.

### MGT020 - 4"

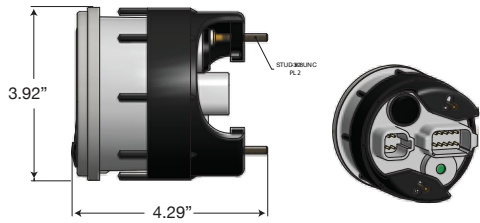

### MGT021 - 5"

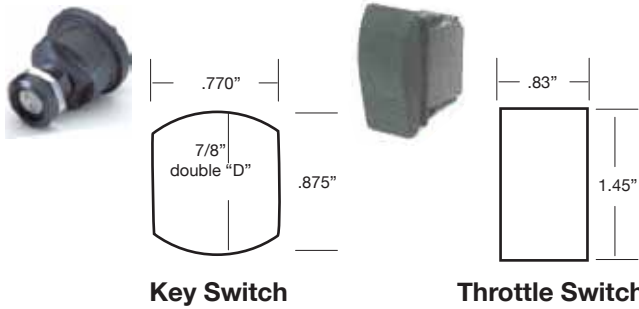
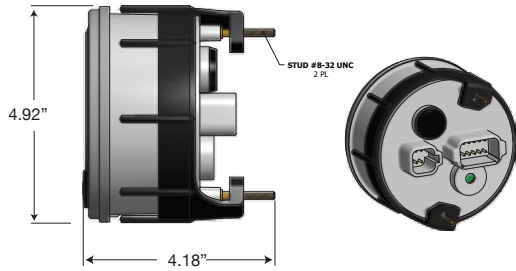

Key Switch

Throttle Switch

### STANDARD FEATURES

- Analog Input for Fuel Level
- Analog Input for Engine Oil Pressure
- User configurable engine speed limits
- Programmable throttle operation
- Engine Maintenance Interval
- SAE J1939 compatible throttle control
- SAE J1939 compatible Diagnostics
- RGB LED backlighting multi-color display lighting
- Multi Language Support
- Remote Engine Shutdown
- Audible and Visual Alarms

### GENERAL

Operating Voltage.....10.5 VDC to 18 VDC  
 Operating Temperature.....-20C to 70C  
 Storage Temperature.....-30C to 85C  
 Reverse Polarity Protection.....Yes  
 Display.....Color LCD 128 x 64

### INPUTS

#### Analog Inputs 2

- 1 Channel Configurable for Fuel Level:
  - 240 to 33 ohms (US)
  - 10 to 180 ohms (EURO)
- 1 Channel Configurable for Oil Pressure:
  - 10 to 180 ohms (0 – 5 BAR)
  - 10 to 180 ohms (0-10 BAR)

#### Digital Inputs 4

- 1 Channel Engine Stop

Active signal: closure to ground

### THROTTLE CONFIGURATION

Ramp - operate within engine range  
 Two State – Set two operating speeds

### System Components

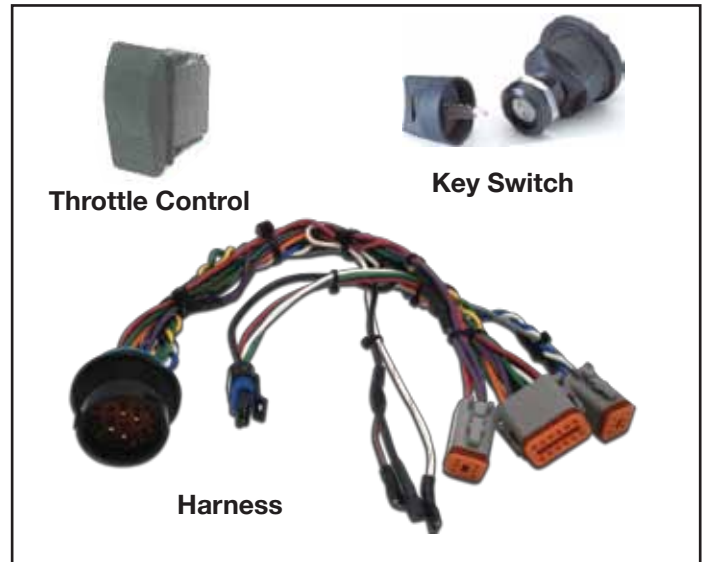

Throttle Control

Key Switch

Harness

### Other Gauges

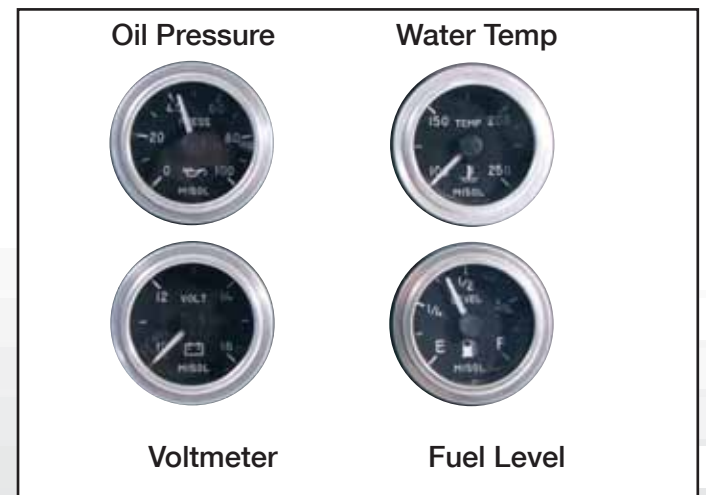

Oil Pressure

Water Temp

Voltmeter

Fuel Level



## Universal M150L20 Series Control Panel

for Electronically Governed Engines

The M150L Series Control Panels are a universal platform of products designed to control J1939 electronically governed engines. With a family of panel configurations ranging from panel mount to single gauge to multi-gauge and a NEMA 4X enclosure virtually any installation can be met. If a panel or enclosure is not required the M150L series offers a kit containing all necessary parts that can be mounted in a customer specific panel design.

With a full featured J1939 interface the M150L series panels provide a complete interface for virtually any SAE J1939 data. With standard features such as “TSC1 Throttle Control”, “Fuel Level Input”, “Engine Oil Pressure” and “Engine Shutdown”, the M150L provides the most features in the price range.

Using the traditional look of a round gauge and the latest microprocessor technology the M150L series products provide the user with a traditional “look and feel” for controlling the latest electronic engines. Incorporating the latest technology allows the M150L products to be fully scalable from a single gauge solution to a full feature multi-gauge applications.

## Universal M150L15 Series Control Panel

for Electronically Governed Engines

With a full featured J1939 interface the M150L15 series panels provide a complete interface for virtually any SAE J1939 data. With standard features such as “TSC1 Throttle Control”, “Fuel Level Input”, “Engine Oil Pressure” and “Engine Shutdown”, the M150L provides the most features in the price range. The gateway interface is available in a 4” or 5” configuration. The M150L15 configuration can be shipped with variety of gauge configurations including; oil pressure, engine temperature, voltage and fuel expansion gauges.

Using the traditional look of a round gauge and the latest microprocessor technology the M150L15 series products provide the user with a traditional “look and feel” for controlling the latest electronic engines. Incorporating the latest technology allows the M150L products to be fully scalable from a single gauge solution to a full feature multi-gauge applications.



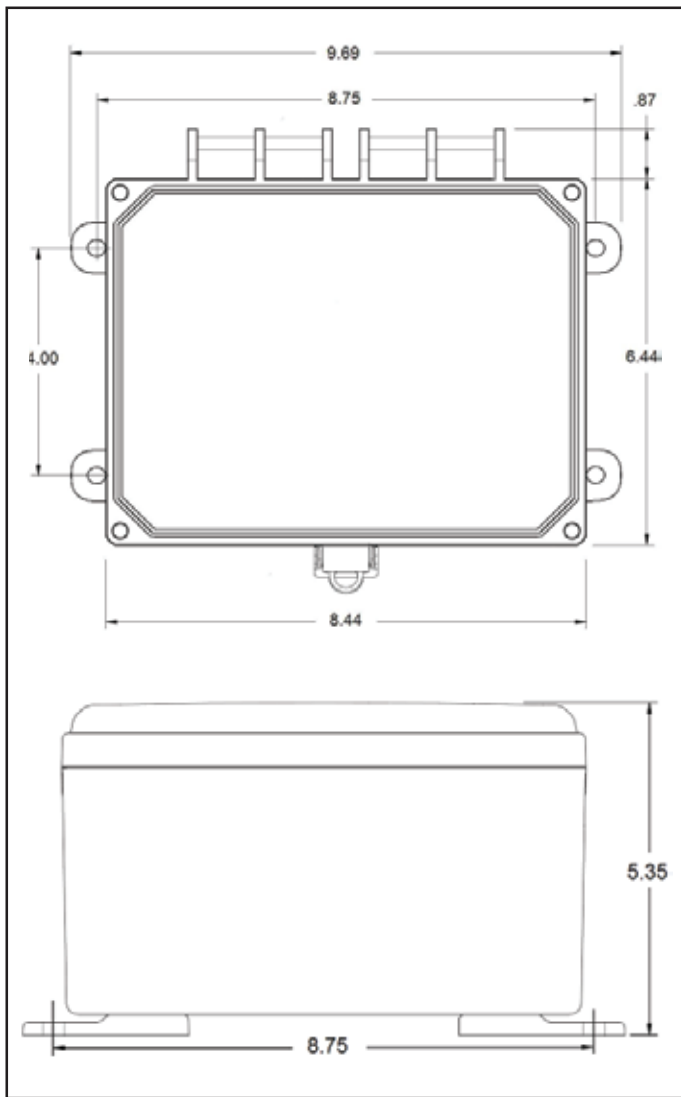

## GENERAL

Operating Voltage.....10.5 VDC to 18 VDC  
 Operating Temperature.....-20C to 70C  
 Storage Temperature.....-30C to 85C  
 Reverse Polarity Protection ..... Yes  
 Display .....Color LCD 128 x 64

### M150L20

Sealed Enclosure..... Poly carbonate NEMA 4x  
 Approx Weight.....3.5 lbs  
 Approx Dimensions .....8”H x 8.5”W x 5.5”D

### M150L15

Enclosure..... 14 ga Roll Steel, welded seams  
 Approx Weight.....8 lbs  
 Approx Dimensions .....16.5”H x 8”W x 4”D

## INPUTS

Analog Inputs 2

- 1 Channel Configurable for Fuel Level:
  - 240 to 33 ohms (US)
  - 10 to 180 ohms (EURO)
- 1 Channel Configurable for Oil Pressure:
  - 10 to 180 ohms (0 – 5 BAR)
  - 10 to 180 ohms (0-10 BAR)

Digital Inputs 4

- 1 Channel Engine Stop

Active signal: closure to ground

## THROTTLE CONFIGURATION

Ramp - operate within engine range

Two State – Set two operating speeds

## STANDARD FEATURES

- Analog Input for Fuel Level
- Analog Input for Engine Oil Pressure
- User configurable engine speed limits
- Programmable throttle operation
- Engine Maintenance Interval
- SAE J1939 compatible throttle control
- SAE J1939 compatible Diagnostics
- RGB LED backlighting multi-color display lighting
- Multi Language Support
- Remote Engine Shutdown
- Audible and Visual Alarms

## INPUTS

- J1939 Engine Data
- Oil Pressure
- Fuel Level
- Remote Engine Stop

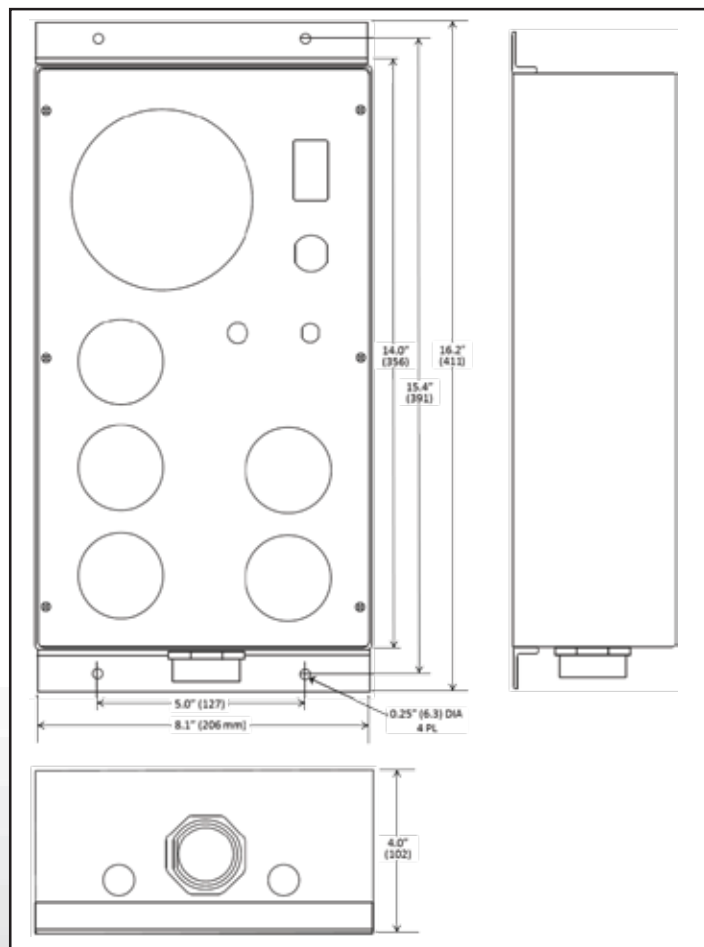



# M150 Pro - Auto Start/Stop Engine Control Panel

for Electronically Governed Engines

The M150 Series Control Panels are a universal platform of products designed to control electronically governed engines. With a full featured J1939 interface the M150 provide a complete interface for virtually any SAE J1939 data. With standard features such as “Auto Start”, “Universal Auxiliary Inputs”, analog inputs for both “oil pressure” and “fuel level” and an output for an audible alarm, the M150 provides the most features in the price range.

## DISPLAY

The 4.25 inch (diagonal) LCD display provides a large viewing area for virtually any data reported by the ECU. The M150 displays diagnostic messages from the ECU per SAE J1939. Engine specific diagnostics messages are available for specified engines. (See part number section for list of specific engine types.)



## ALARMS

The M150 displays diagnostic messages from the ECU per J1939 format. An active alarm display and an ECU generated historical alarm data display provide the user with easy access to system operation.

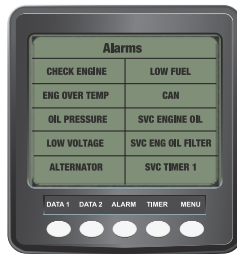

## PANEL

The M150 standard panel terminates to a sealed Deutsch weatherproof connect. For weatherproof conditions the M150 can be provided in a NEMA 4X housing.

## REMOTE SPEED CONTROL

The M150 Series Control Panel provides three user configurable engine speed settings. These speed settings can be set to any engine rpm within the min and max rpm range of the engine. An engine speed setting can be assigned to one of three available digital inputs allowing the M150 system to be configured for most field applications. The digital inputs provide complete flexibility for the user by allowing the input to be activated with a contact closure to ground or connection to V battery.

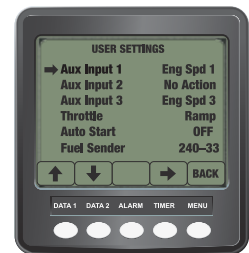
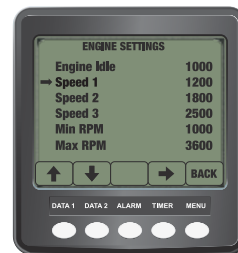

## REMOTE ENGINE STOP

Remote Engine Stop is a user configurable input to remotely stop the engine. An engine stop setting can be assigned to one of three available digital inputs allowing the M150 system to be configured for most field applications. When the assigned digital input is activated the M150 system will shut the engine down. The digital inputs provide complete flexibility for the user by allowing the input to be activated with a contact closure to ground or connection to V battery. A typical use for the remote engine stop feature is a safety application requiring an emergency stop mechanism; such as “Man Off Seat”.

## THROTTLE CONTROL

A single momentary rocker switch adjusts the engine speed via CAN Bus communications to the engine. The throttle functionality is user selectable allowing the rocker switch to provide a smooth ramp function or a fixed rpm 2-State setting. Universal auxiliary inputs allow the user to define remote throttle control values.

## AUTOMATIC START / STOP

The M150 provides Automatic Start / Stop control utilizing a switch input for remote control of engine start / stop. The auto start / stop feature along with three remote speed inputs give the M150 a wide range of configurability to meet most any customer need.



## REMOTE ENGINE START PROTECT

Remote Engine Start Protect is a user configurable input to remotely prevent unwanted engine starts. An engine start protect setting can be assigned to one of three available digital inputs allowing the M150 system to be configured for most field applications. When the assigned digital input is active the M150 allows the engine to start. Should the input be inactive the engine will not start and the M150 will provide a popup display alerting the operator. Once the engine has started this input has no affect on the engine operation. A typical use of the remote engine start protect feature is a safety application requiring a device be disengaged prior to engine start.



## FUEL LEVEL

User configurable analog input for fuel level sensors. US 240-33 and Euro 10-180 ohm senders can be selected.

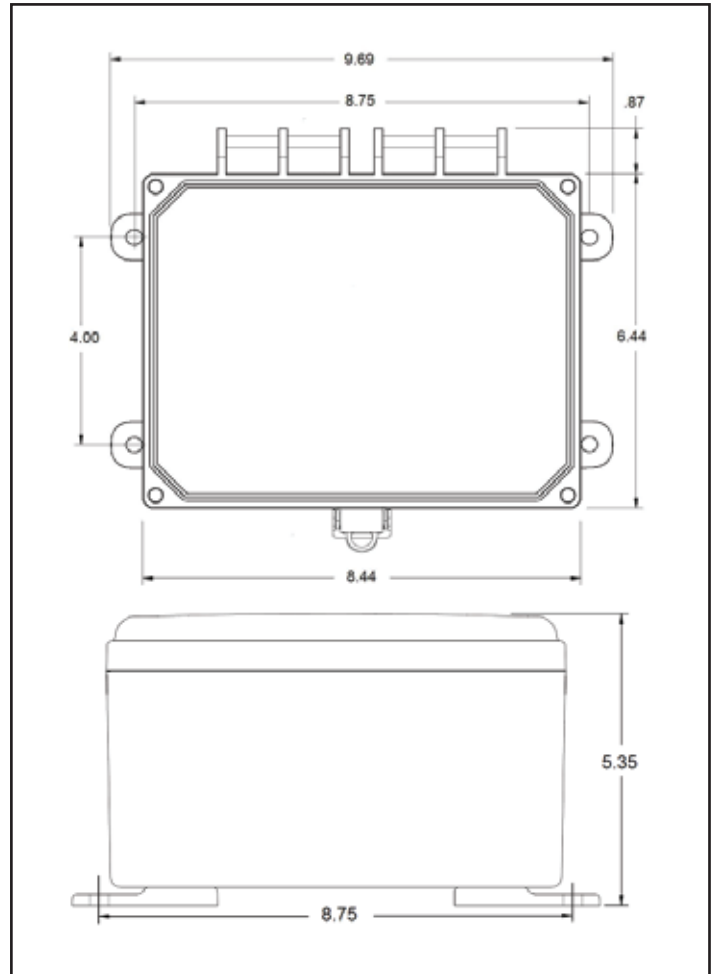

## STANDARD FEATURES

- Auto Start
- Analog Input for Fuel Level
- Analog Input for Engine Oil Pressure
- User configurable engine speed limits
- Remote engine speed selection
- Programmable throttle operation
- SAE J1939 compatible throttle control
- SAE J1939 compatible Diagnostics
- Audible and Visual Alarms
- External 3A Ignition Power

## INPUTS

- J1939 Engine Data
- Oil Pressure
- Fuel Level
- Remote Speed Selection
- Remote Start Protect
- Remote Engine Stop

## GENERAL

Operating Voltage..... 6.0 VDC to 16 VDC  
 Operating Temperature..... -25C to 75C  
 Storage Temperature..... -40C to 80C  
 Reverse Polarity Protection..... Yes  
 Display.. ..... Monochrome LCD 160 x 128  
 Enclosure..... Poly carbonate NEMA 4x  
 Approx Weight..... 3.5 lbs  
 Approx Dimensions ..... 8"H x 8.5"W x 5.5"D

## INPUTS

Analog Inputs ..... 2  
 - 1 Channel Configurable for Fuel Level:  
 - 240 to 33 ohms (US)  
 - 10 to 180 ohms (EURO)  
 -1 Channel Configurable for Oil Pressure:  
 - 10 to 180 ohms (0 – 80 PSI)

Digital Inputs ..... 4  
 -1 Channel Auto Start/Stop active voltage signal >6.5VDC  
 -3 Channels Configurable for either  
 - Start Protect  
 - Engine Stop  
 - Engine Speed 1 thru 3

Active signal: closure to ground or voltage > 6.5VDC

## OUT PUTS

Ignition (3A) continuous (5A Peak) ..... 1  
 Solid State Relay (close to gnd) 1A..... 1

## THROTTLE CONFIGURATION

Ramp - operate within engine range  
 Two State – Set two operating speeds



**Made in the USA**

Uncasville, Connecticut



Made in the USA

**Faria Beede Instruments, Inc.**

P. O. Box 983  
Uncasville, CT 06382  
860.848.9271  
Fax: 860.848.2704

88 Village Street  
Penacook, NH 03303  
603.753.6362  
Toll-free: 800.451.8255  
Fax: 603.753.6201