



Universal L20 Series Control Panel

for Electronically Governed Engines

DESCRIPTION

The M150L Series Control Panels are a universal platform of products designed to control J1939 electronically governed engines. With a family of panel configurations ranging from panel mount to single gauge to multi-gauge and a NEMA 4X enclosure virtually any installation can be met. If a panel or enclosure is not required the M150L series offers a kit containing all necessary parts that can be mounted in a customer specific panel design.

With a full featured J1939 interface the M150L series panels provide a complete interface for virtually any SAE J1939 data. With standard features such as "TSC1 Throttle Control", "Fuel Level Input", "Engine Oil Pressure" and "Engine Shutdown", the M150L provides the most features in the price range.

Using the traditional look of a round gauge and the latest microprocessor technology the M150L series products provide the user with a traditional "look and feel" for controlling the latest electronic engines. Incorporating the latest technology allows the M150L products to be fully scaleable from a single gauge solution to a full feature multi-gauge applications.



DISPLAY

The 128x64 LCD display provides an easy to read viewing area for system configuration and virtually any data reported by the ECU.

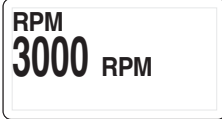

THROTTLE CONTROL

A single momentary rocker switch adjusts the engine speed via CAN Bus communications to the engine. The throttle functionality is user selectable allowing the rocker switch to provide a smooth ramp function or a fixed rpm 2-State setting.



ENCLOSURE

All M150L20 Series Control Panels are provided in a sealed NEMA 4X housing which terminates to a sealed Deutsch weatherproof connector.

CONNECTOR

A water tight 21-pin connector is used for plug-in installation.

STANDARD FEATURES

- Analog Input for Fuel Level
- Analog Input for Engine Oil Pressure
- User configurable engine speed limits
- Programmable throttle operation
- Engine Maintenance Interval
- SAE J1939 compatible throttle control
- SAE J1939 compatible Diagnostics
- RGB LED backlighting multi-color display lighting
- Multi Language Support
- Remote Engine Shutdown
- Audible and Visual Alarms

INPUTS

- J1939 Engine Data
- Oil Pressure
- Fuel Level
- Remote Engine Stop

CONFIGURABLE ENGINE SPEED LIMITS

The L20 Series Control Kit provides the user with two configurable engine speed settings. These speed settings can be set to any engine rpm within the min and max rpm range of the engine. One speed setting for minimum engine speed (i.e. idle) and the other speed setting for maximum engine speed (i.e. engine run speed)

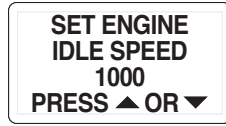

ALARMS

The M150L displays diagnostic messages from the ECU per J1939 format. All DM1 and DM2 diagnostic messages from the Engine ECU are reported. Engine specific diagnostics messages are available for specified engines. (See part number section for list of specific engine types.) Alarms are indicated with a Red LCD display backlight. Warnings are indicated with an Amber LCD display backlight.



ENGINE SHUTDOWN

A contact closure to ground for Engine Shutdown is provided as a customer input. When activated the M150L System will remove ignition voltage to the engine stopping the engine. The system will provide an alarm popup screen to signal the operator that the engine was remotely shutdown.



FUEL LEVEL

User configurable analog input for fuel level sensors. US 240-33 and Euro 10-180 ohm senders can be selected.

OIL PRESSURE

User configurable analog input for 0-5 and 0-10 BAR can be selected.

MAINTENANCE INTERVAL

User configurable maintenance interval. When programmed system provides warning message when maintenance interval has expired.

AVAILABLE PARTS

- M150L20-00 CP; Eng Ctrl J1939 , T3, 4 in Tach - enclosure
- M150L20-10 CP; Eng Ctrl, Yanmar TNV T3, 4 in Tach - enclosure
- M150L20-20 CP; Eng Ctrl JCB T3, 4 in Tach - enclosure
- M150L20-50 CP; Eng Ctrl J1939 T3, 5 in Tach - enclosure - FUTURE
- M150L20-60 CP; Eng Ctrl Yanmar T3, 5 in Tach - enclosure - FUTURE
- M150L20-70 CP; Eng Ctrl JCB T3, 5 in Tach - enclosure - FUTURE
- M155L20-00 CP; Eng Ctrl J1939 T4, 4 in Tach - enclosure - FUTURE
- M155L20-20 CP; Eng Ctrl JCB T4, 4 in Tach - enclosure - FUTURE

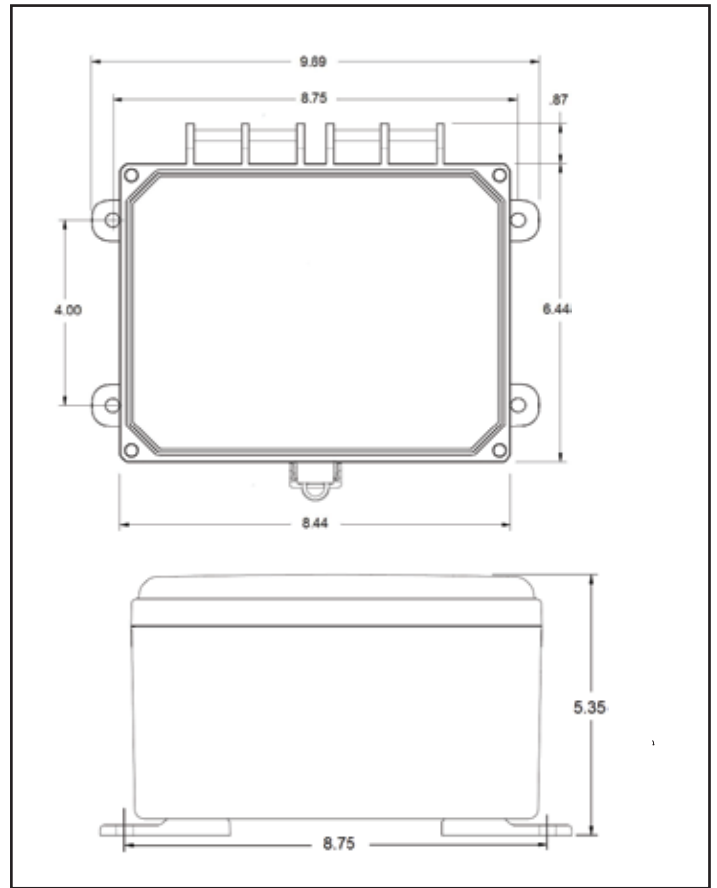

SPECIFICATIONS

GENERAL

- Operating Voltage.....10.5 VDC to 18 VDC
- Operating Temperature.....-20C to 70C
- Storage Temperature.....-30C to 85C
- Reverse Polarity Protection.....Yes
- DisplayColor LCD 128 x 64
- Sealed Enclosure..... Polycarbonate NEMA 4x
- Approx Weight.....3.5 lbs
- Approx Dimensions8"H x 8.5"W x 5.5"D

INPUTS

Analog Inputs 2

- 1 Channel Configurable for Fuel Level:
 - 240 to 33 ohms (US)
 - 10 to 180 ohms (EURO)
- 1 Channel Configurable for Oil Pressure:
 - 10 to 180 ohms (0 – 5 BAR)
 - 10 to 180 ohms (0-10 BAR)

Digital Inputs 4

- 1 Channel Engine Stop

Active signal: closure to ground

THROTTLE CONFIGURATION

- Ramp - operate within engine range
- Two State – Set two operating speeds

For more information:

Thomas G. Faria Corporation
 P.O. Box 983
 385 Norwich-New London Turnpike
 Uncasville, CT 06382
 t. 860.848.9271
 f. 860.848.2704