



Gateway Systems

for CAN Bus engines

DESCRIPTION

The digital gateway systems, available in the Speedometer or Tachometer, is a feature-rich, intuitive engine monitoring solution for the instrument market.

The digital instrumentation communicates directly with the J1939, NMEA2000 and SmartCraft protocols used by the engine ECU providing an important link between the operator and the engine ECU. With just a push of a button the operator can tell the status of the health of the engine including diagnostic messages, fault alerts, and parameter information.

With a full featured J1939 interface the MG3000 series instruments provide a complete interface for virtually any SAE J1939 data.

Connect to analog and digital signals to reduce installed costs significantly.

The MG3000 and other digital instruments from Faria are fully scalable from a single gauge solution to a full feature multi-gauge applications.

DISPLAY

The 128x64 color LCD display, available on the MG3000, provides an easy to read viewing area for system configuration and virtually any data reported by the ECU. The new daylight readable LCD is visible even in direct sunlight.

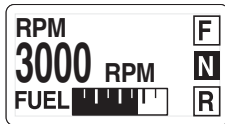

Yellow	Cyan	Goldenrod
Gr.Yellow	Blue	Tan
Green	Purple	White
Dk Sea Green	Pink	

The display is available with multiple RGB colors.

INTERFACE

The MG3000 can be configured with or without the three front-mounted push button function selectors. These buttons control the user configurable software and provide access to variable menus and selections.

The MG3000 also allows for remote input device for control of the screens and data viewing.

GRAPHICS

Faria can help design your own custom graphics. Many dial ranges and scales are available including lens type, bezel color, pointer color and back-lighting.

ENCLOSURE

The enclosure is molded from Polycarbonate plastic with integrated Deutsch style connector shells (sockets) and is sealed against water intrusion in accordance with Ingress Protection (IP) rating IP67. Wires terminate to a sealed Deutsch weatherproof connector.

The case is available in three water tight configurations from fully waterproof to vented.

Depending on instrument type the case is available in 2, 4 and 5 inch standard hole sizes.



SAE J1939

STANDARD FEATURES

- Tier 4 Compatible
- LCD data are available in 5 languages.
- Seasonal and Trip Data.
- Pop-Up screens for quick information display and warnings.
- Alarm codes with suggested actions.
- Data log for fault codes.
- A single Gateway instrument can monitor up to 5 tanks or other analog signals.
- Calibrate Fuel Level and Speed in gauge.
- Initialization mode to assist in gauge set-up.
- Superior Sunlight readable display.
- Units can be displayed in US standard or Metric
- Gear position indicators

INPUTS

- CAN Bus (J1939, NMEA2000 and SmartCraft)
- Direct Pressure (30 PSI -200 kP) and (145 PSI - 10000kP)
- Analog Inputs
5 Analog inputs are available (Customer specific)

ACCURACY

A digital stepper motor drives the pointers in Faria's digital instruments. The stepper motor increases the accuracy and reliability of the instrument while reducing jittery pointers and providing longer life with a lower power requirement.

CONNECTORS

A water tight 12-pin and 6-pin connector is used for plug-in installation.

ALARMS

The MG3000 displays diagnostic messages from the ECU per J1939 format. All DM1 and DM2 diagnostic messages from the Engine ECU are reported. Engine specific diagnostics messages are available for specified engines. Alarms are indicated with a Red LCD display backlight. Warnings are indicated with an Amber LCD display backlight.



FUEL LEVEL

User configurable analog input for fuel level sensors. US 240-33 and Euro 10-180 ohm senders can be selected.

MAINTENANCE INTERVAL

User configurable maintenance interval. When programmed system provides warning message when maintenance interval has expired.

OTHER AVAILABLE FUNCTIONS

Other functions are available, including;

Engine Temperature	Trip Data
Air Temperature	Engine Hours
Exhaust Temperature	Odometer A, B and Seasonal
Oil Temperature	Fuel Used
Water Temperature	Average Fuel
Oil Pressure	Fuel Management
Manifold Pressure	Fuel Flow
Water Pressure	Fuel Left
Max Speed	Fuel Economy
Fuel Level	Fuel Instantaneous
Oil Level	Fuel Used
Tank Level	Total Fuel (for more than one tank.)
Throttle Position	Battery
Engine Load	Clock
	Position

DISCRETE GAUGES

Multiple discrete gauges are available in multiple configurations including Multifunction instruments and individual gauges. Each gauge is daisy chained into the system simplifying installation. Add up to 10 gauges from a single gateway systems instrument.

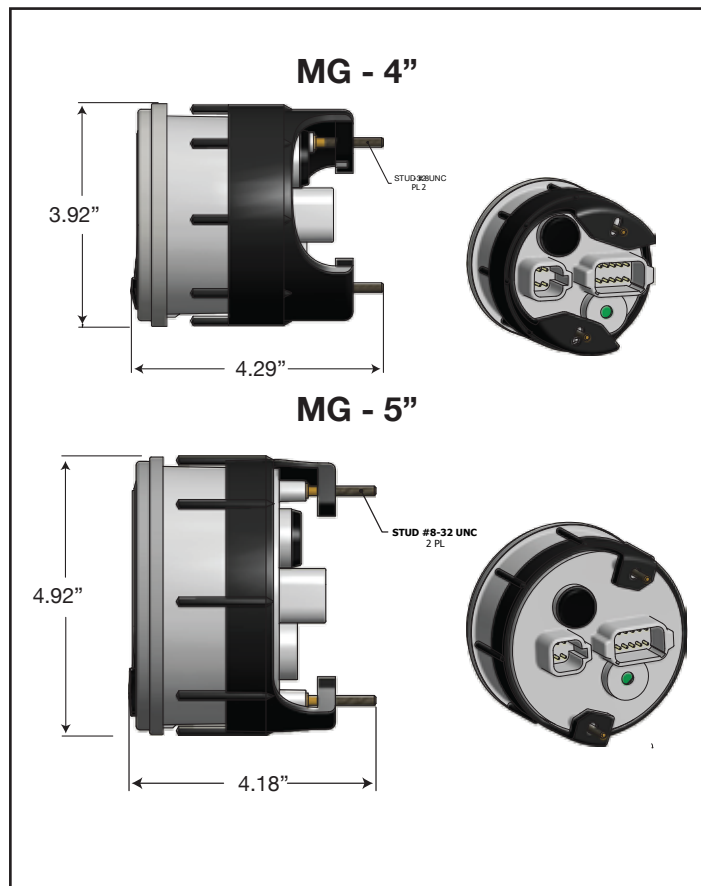

SPECIFICATIONS

GENERAL

Operating Voltage.....11.5 VDC to 16 VDC

Operating Temperature.....-20C to 70C

Storage Temperature.....-30C to 85C

Reverse Polarity Protection.....Yes

Display. ...Color LCD 128 x 64 (available on MG3000)

Shock

50 +/- 2 G and a half sine duration of 11 +/- 2 ms. per

MIL-STD-202, Method 213

Vibration

4 G peak, 10 to 200Hz

SAE J1455 Appendix A

Salt Spray

Front is Corrosion resistant per ASTM B117-73

Weather Resistance

Instrument has been tested to resist weather conditions in accordance with IP67 standards.

For more information:

Thomas G. Faria Corporation
P.O. Box 983
385 Norwich-New London Turnpike
Uncasville, CT 06382
t. 860.848.9271
f. 860.848.2704