

Reduce cost with entry level digital engine monitoring.

The MG1000 is the stepping stone of digital instrumentation. This innovative digital gauge system requires no LCD's, no system initialization, no menu setups and no user manual interaction for use - ever! Just install and go boating!

The MG1000 gauge system displays engine ECU data and alarms. Installation is simplified by reducing wiring and setup time. Our instruments communicate with the engine ECU for the most accurate information and error codes.

This system is the lowest cost, most user-friendly digital product in the market for customers installing digital technology. Multiple analog inputs and warning lights reduce cost while still providing the customer with everything they need.

Upgrade to the MG3000 system for an even wider variety of options and features. The Faria product suite offers a multitude of accessory gauges available to connect to the MG1000 system including a 2" fuel flow gauge to show fuel economy. The combinations are limitless!!

Compatible with MG3000 systems.

- Can be directly connected to NMEA2000 systems
- NMEA0183 input for GPS Speed
- A single Tachometer can monitor up to 4 fuel tanks
- Use to monitor up to 5 engines
- Add additional features, connect the MG3000 with the same harness
- Utilizes both analog and digital inputs to reduce system cost
 - Speed
 - Fuel
 - Trim
 - Water pressure
 - Temperatures
- Stepper motor gauges (for greater accuracy and durability)
- Deutsch and Packard marine connectors
- LED lighting is standard
- Custom cosmetic options upon request
- Multiple 5"/4"/2" discrete instruments are available

Specifically designed to work with the leading engine manufacturers.

The MG1000 displays the critical data and information that boaters demand in a simple, lower-cost, intuitive package.

Accuracy

A digital stepper motor drives the pointers in Faria's digital instruments. The stepper motor increases the accuracy and reliability of the instrument while reducing jittery pointers and providing longer life with a lower power requirement.

Connectors

A water tight 12-pin and 6-pin connector is used for plug-in installation.

Enclosure

The enclosure is molded from Polycarbonate plastic with integrated Deutsch style connector shells (sockets) and is sealed against water intrusion in accordance with Ingress Protection (IP) rating IP67. Wires terminate to a sealed Deutsch weatherproof connector.

The case is available in three water tight configurations from fully waterproof to vented.

Depending on instrument type the case is available in 2, 4 and 5 inch standard hole sizes.



Faria Corporation
P. O. Box 983
Uncasville, CT 06382
860.848.9271
Fax: 860.848.2704

Beede Instrument Company, Inc.
88 Village Street
Penacook, NH 03303
603.753.6362
Toll-free: 800.451.8255
Fax: 603.753.6201

 Made in the USA

fm-001-0020 rev F 02/2014



Graphics

Faria can help design your own custom graphics. Many dial ranges and scales are available including lens type, bezel color, pointer color and back-lighting.

Discrete Gauges

Multiple discrete gauges are available in multiple configurations including Multifunction instruments and individual gauges. Each gauge is daisy chained into the system simplifying installation. Add up to 10 gauges from a single gateway systems instrument.

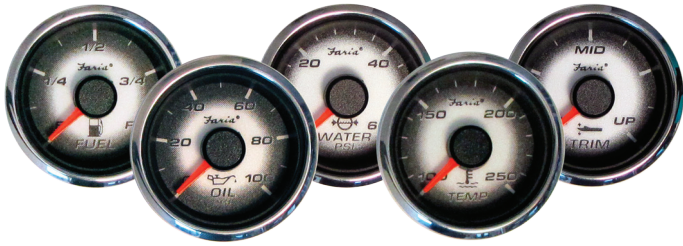

MG - 4"

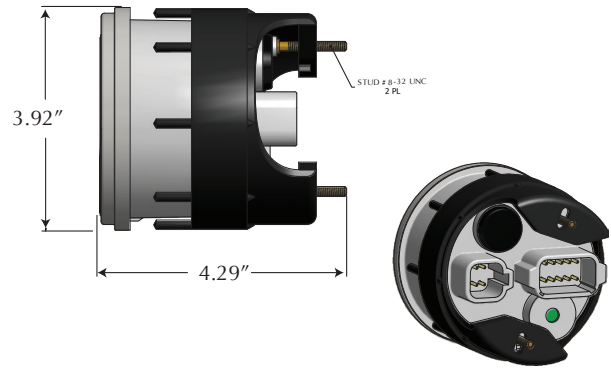

MG - 5"

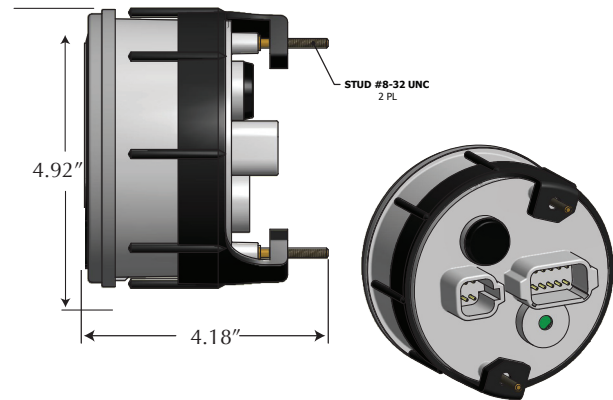

Specifications

GENERAL

Operating Voltage..... 11.5 VDC to 16 VDC
Operating Temperature-20C to 70C
Storage Temperature-30C to 85C
Reverse Polarity ProtectionYes

Shock

50 +/- 2 G and a half sine duration of 11 +/- 2 ms. per MIL-STD-202, Method 213

Vibration

4 G peak, 10 to 200Hz
SAE J1455 Appendix A

Salt Spray

Front is Corrosion resistant per ASTM B117-73

Weather Resistance

Instrument has been tested to resist weather conditions in accordance with IP67 standards.