



MIL-SPEC Instrumentation for more than 30 years



With some of the most sophisticated information and instrumentation systems in the industry, and a range of products that are rugged enough to survive on military Humvee and heavy construction equipment, or with innovative styling for your boat or RV, Thomas G. Faria Corporation has the right products to meet future global needs for rugged, reliable, and innovative instrumentation.



An ISO9001-2008 Registered Company

For more than 50 years Faria has been dedicated to the principle of supplying our customers with the highest quality product at the most competitive prices.

All Faria instruments are performance proven under the most demanding conditions. They are factory installed original equipment with major manufacturers worldwide. You can rely on Faria Instruments for world class quality, dependability and ease of installation.

Our years of manufacturing experience and knowledge of the industries we sell to have taught us to listen to the market place. Our in-house product design and development, component manufacture and instrument assembly allow us to respond quickly to your needs.

The company-wide use of Statistical Process Control (SPC), not only for ourselves but by our vendors as well, allow us to maintain a consistently high standard. In 1998, our efforts were recognized by the world as we became an ISO9001 registered company. We continually reaffirm our commitment to this standard and are now registered as a ISO9001:2008 company.

With the recent purchase of Beede Instruments of Penacook, NH, Faria has expanded our manufacturing capabilities to offer a broader product offering, unsurpassed value and design for all of our markets, including the US Military, industrial, recreational and majority of the world's leading boat manufacturers.

We support our products with a comprehensive Limited Warranty. Should you need them, our dedicated Customer Service Technical Experts are ready to provide installation, troubleshooting and warranty assistance.

Instruments for
Automotive
Commercial
Industrial
Performance
Recreational
Marine
Military



Rugged • Reliable • Innovative



J-1939 CAN Bus Gauges

The digital gateway systems, available in the Speedometer or Tachometer, is a feature-rich, intuitive engine monitoring solution for the instrument market.

The digital instrumentation communicates directly with the J-1939, NMEA2000 and SmartCraft protocols used by the engine ECU providing an important link between the operator and the engine ECU. With just a push of a button the operator can tell the status of the health of the engine including diagnostic messages, fault alerts, and parameter information.

With a full featured J-1939 interface the CAN Bus instruments provide a complete interface for virtually any SAE J-1939 data.

Connect to analog and digital signals to reduce installed costs significantly.

The digital instruments from Faria and Beede are fully scalable from a single gauge solution to a full feature multi-gauge applications.

A user friendly digital engine monitoring solution.

Features and Benefits

- CAN Protocol support for: SAE J-1939, NMEA2000®, SmartCraft®, Indmar (MEFI-4)
- Large transfective dot matrix LCD display
- Advanced stepper motor technology
- 250° pointer deflection on all instruments for increased resolution
- Bright LED illumination
- Visual alert indicators standard on all minor node instruments
- Bold, easy to read graphics
- Real glass lenses available as domed or flat

INPUTS

- Master Node Instrument supports up to three discrete analog sender inputs including NMEA 0183 (GPS/Smart Transducer)

MG3000



Features and Benefits

- Tier 4 Compatible
- LCD data are available in 5 languages.
- Seasonal and Trip Data.
- Pop-Up screens for quick information display and warnings.
- Alarm codes with suggested actions.
- Data log for fault codes.
- A single Gateway instrument can monitor up to 5 tanks or other analog signals.
- Calibrate Fuel Level and Speed in gauge.
- Initialization mode to assist in gauge set-up.
- Superior Sunlight readable display.
- Units can be displayed in US standard or Metric
- Gear position indicators

INPUTS

- CAN Bus (J-1939, NMEA2000 and SmartCraft)
- Direct Pressure (30 PSI -200 kP) and (145 PSI - 10000kP)
- Analog Inputs
5 Analog inputs are available (Customer specific)

NexSysLink[®]
CAN-based instruments



J-1939 Stand-Alone CAN Bus Gauges



Features and Benefits

- J-1939 CAN Bus Instruments
- Stand-Alone technology - Each instrument receives information directly from the J-1939 Bus
- Can be connected in standard J-1939 harness configurations
- Customize to fit your needs

Customizable Features

Bezel profile, material & finish
Dial face graphics & colors
LCD Illumination color

Discrete Gauges Available

A full line of J-1939 Stand-Alone discrete gauges are available. Each gauge connects directly to the J-1939 CAN Bus and can be used with or without a Master unit.

The Discrete Gauges are available with warning lights and a wide variety of functions and scales.



J-1939 started as a communication and diagnostics tool in the car and heavy duty truck industry, J-1939 is quickly becoming the norm in engine communications bus data for many more industries. Faria has worked with this protocol from its beginning. Today we provide many solutions for the different industries to have adopted J-1939 including J-1939 Stand-Alone instruments.

Faria's J-1939 Stand-Alone instruments are designed to plug directly on to the SAE J-1939 bus. Each instrument uses CAN bus data to provide the operator the information in a familiar Analog display. Because each instrument talks directly to the J-1939 CAN bus each instrument provides a redundant source of information. Faria offers the Stand-Alone instrument in a wide range of scale and styles. Many of the instruments can be used in Tier 4 applications. Best used where the operator only needs a few instruments to monitor the engine.

Controlling Specifications

12480561 – TACOM Waterproofness Requirement for Automotive Electrical Components (Class II, Test Type I)

AN/PVS-14 – Monocular Night Vision Device (MNVD)

FED-STD-595 – Colors Used in Government Procurement

MIL-STD-130F

MIL-STD-202G

MIL-STD-461E – Requirements for the Control of Electromagnetic Interference

MIL-STD-464A – Electromagnetic Environmental Effects

MIL-STD-810 (A-F) – Test Method Standard for Environmental Engineering Considerations and Laboratory Tests

MIL-STD-1179D – Lamps, Reflectors and Associated Signaling Equipment for Military Vehicles

MIL-STD-1275D – Characteristics of 28 Volt DC Electrical Systems in Military Vehicles

MIL-DTL-12468 – Decontaminating Agent, Super Tropical Bleach (STB)

SAE – Society of Automotive Engineers

J1113-13 – Electromagnetic Compatibility Measurement Procedure for Vehicle Components – Part 13: Immunity to Electrostatic Discharge

J1455 – Recommended Environmental Practices for Electronic Equipment Design in Heavy-Duty Vehicle Applications (Transient, Temperature & Humidity, Shock and Vibration, Salt Spray)

J1939 – Recommended Practice for a Serial Control and Communications Vehicle Network STANAG 4381 – Blackout Lighting Systems for Tactical Land Vehicles

HALT (Highly Accelerated Life Testing) – where appropriate

J-1939 Speedometer



The J-1939 Speedometer is a Stand-Alone CAN bus instrument designed to connect directly to the J-1939 CAN system.

The speed information is received directly from the ECM and is indicated using an analog style pointer driven by the digital stepper motor for a more accurate and reliable reading. Speed can be read in MPH major increments (outer) and KPH (inner increments), as MPH only, KPH only or KPH major increment (outer) and MPH (inner increments).

Odometer and other data features are displayed on the 7 character LCD display.

Functions Displayed in the LCD

- Odometer**
- Trip Counter**
- Oil Pressure**
- Coolant Temperature**
- Battery Potential (Voltage)**
- Fuel Flow (GPH)**
- Engine Hours**
- Clock**
- Transmission Gear**
- Alarm (Code)**
Shown only when alarms active

Specifications

General:

Mounting Hole: 3.375" (85 mm)
Depth behind face plate: 4" (100 mm) min.

Cosmetic:

Dial: Aluminum
Dial Printing colors: Green (24172)
Yellow (23655)
Red (21136)
White (37875)
Black (37038)

Mask: Molded plastic
Pointer: Molded plastic
counter balanced
Backlighted clear
Ambient lighted white

Lens: Flat Glass
Bezel: Military or SAE style
(flat front, stepped profile)
Stainless steel
Black anodized aluminum

Backlighting: Perimeter Lit Dial with LEDs
Lights turn on when power is applied.

Display: Single line 7 character display
14 segments per character
LED backlight
Sunlight readable
NVIS B compatible backlight
LCD may incorporate heater

Operational:

Mounting Bracket: Plastic
Clamping Range: 0 - .8 in (0-20 mm)
Torque: up to 10 inch pounds (.57 - 80 Nm.)

Connector: Deutsch DT04-6P (6 -pin, 1x or 2x)

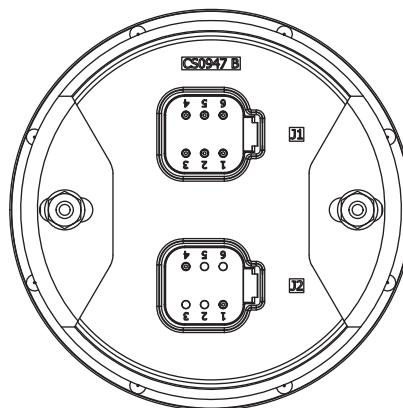

Rear view with back clamp

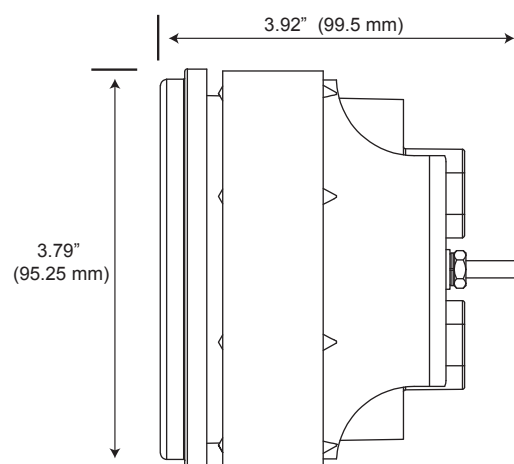

J-1939 Stand-Alone CAN Bus display



Instrument Shown
Actual Size



Configurable Two Line Display

Features and Benefits

- SAE J-1939 CAN protocol support
- Compact packaging
- 32 X 128 dot matrix graphic LCD
- Displays active and stored faults (SAE J-1939 DM1 & DM2)
- Single or Dual Line Display
- Three discrete LED indicators
- Alarm output capable of switching up to 150 mA
- Built in audible alarm (mutable)
- Built-in, sealed, tactile rubber keypad
- Bright, adjustable LED illumination
- Environmentally sealed connectors

Customizable Features

Bezel profile, material & finish
Dial face graphics & colors
LCD Illumination color



SAE J1939

NexSysLink[®] CAN Instruments Product Family

The NexSysLink CAN Bus display instrument reads and processes SAE J-1939 compliant CAN messages.

The sunlight visible, transfective LCD displays operating parameters and is complemented by three discrete alert LED's.

An intuitive menu driven user interface accessed by three built-in tactile switches allows for easy display configuration. Stand-alone and Master Node (MNI) configurations available. MNI configuration drives NexSysLink[®] SNI & ASNI gauges.

SAE J-1939 Parameter Set*

Parameter Name	SPN	Parameter Name	SPN
Accelerator Pedal Position	91	Fuel Rate	183
Alternator Voltage	167	Engine Fuel Temperature	174
Battery Current	114	Engine Hours	247
Battery Voltage	168	Engine Oil Level	98
Boost Pressure	102	Engine Oil Pressure	100
Coolant Level	111	Engine Oil Temperature	175
Coolant Pressure	109	Hydraulic Oil Level	2602
Coolant Temperature	110	Hydraulic Temperature	1638
DEF Level	1761	Intercooler Temperature	52
DEF Temperature	3031	Percent Load	92
Engine Speed (RPM)	190	Vehicle Miles	245/917
Exhaust Gas Temperature	173	PTO Speed	186
Fuel Economy (Average)	185	Engine Throttle Position	51
Fuel Level 1	96	Vehicle Speed	84
Fuel Level 2	38	Transmission Oil Level	124
Fuel Delivery Pressure	94	Transmission Oil Pressure	127
		Transmission Oil Temperature	177

*Only actively broadcast parameters appear on the LCD.

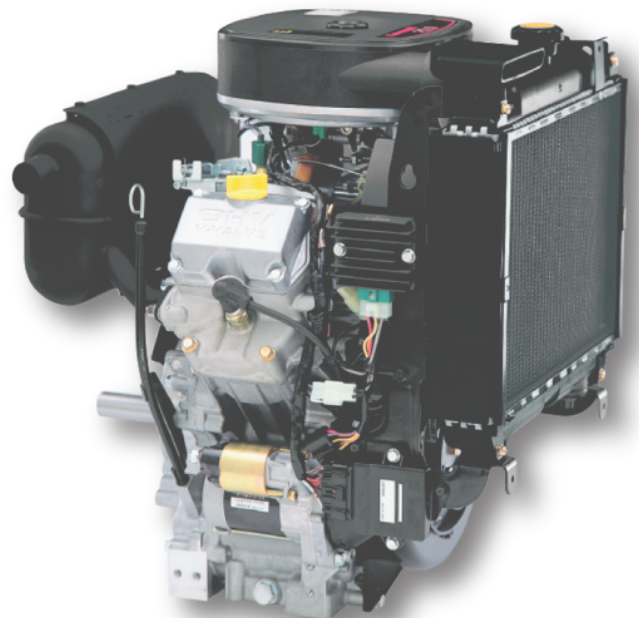

J-1939 CAN Bus Panels, Clusters and Instruments



New designs, including the popular MG3000 digital LCD display, adds the features of our best selling digital instrument in a single panel cluster design. Customize your panel with warning lights and discrete gauge functions.

Features and Benefits

- J-1939 CAN Bus Instruments
- Stand-Alone technology - Each instrument receives information directly from the J-1939 Bus
- Available in a wide variety of styles
- Designed and manufactured to MIL-STD-1275, MIL-STD-465, MIL-STD-464, MIL-STD-810 and SAE J113-13 specifications
- Multiple Analog and Digital Inputs to reduce system costs
- Made in the USA
Uncasville, CT
Penacook, NH
- Wide variety of instruments including 3-1 and 4-1 multi-function gauges, 4-inch and 5-inch Speedometers and Tachometers and a complete suite of 2-inch discreet instruments i.e, Fuel Level, Temperature, Volts and Oil Level



SAE J1939

J-1939 Tell-Tale Indicator with 30 Icon Positions

NexSysLink®
CAN Instruments Product Family



Features and Benefits

- Environmentally sealed connectors
- Custom icon configurations available
- Up to ten discrete inputs switched either high or low
- SAE J-1939 CAN protocol support
- Connects seamlessly with **NexSysLink** MNI instruments
- Bright LED illuminated tell-tales
- Built in audible alarm and switched output

This CAN based product complements the **NexSysLink®** instrument system by providing thirty LED illuminated operator alert tell-tales along with an audible alarm to alert users to multiple fault conditions.

Product Description

The alert panel directly reads and processes SAE J-1939 compliant CAN messages, serial data from any NexSysLink Master Node Instrument and up to ten factory configurable discrete inputs switched either high or low to activate the tell-tales and/or audible alarm.

A discrete output capable of switching up to one amp and an audible output increase the utility of this product.

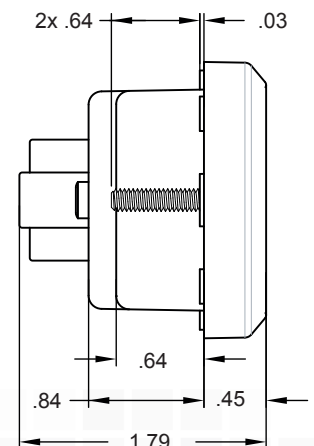

SAE J1939



Front View

Control Panels and Instruments for Electronically Governed Engines



Universal M150L20 Series Control Panel for Electronically Governed Engines

The M150L Series Control Panels are a universal platform of products designed to control J-1939 electronically governed engines. With a family of panel configurations ranging from panel mount to single gauge to multi-gauge and a NEMA 4X enclosure virtually any installation can be met. If a panel or enclosure is not required the M150L series offers a kit containing all necessary parts that can be mounted in a customer specific panel design.

With a full featured J-1939 interface the M150L series panels provide a complete interface for virtually any SAE J-1939 data. With standard features such as "TSC1 Throttle Control", "Fuel Level Input", "Engine Oil Pressure" and "Engine Shutdown", the M150L provides the most features in the price range.

Using the traditional look of a round gauge and the latest microprocessor technology the M150L series products provide the user with a traditional "look and feel" for controlling the latest electronic engines. Incorporating the latest technology allows the M150L products to be fully scalable from a single gauge solution to a full feature multi-gauge applications.

Universal M150L15 Series Control Panel for Electronically Governed Engines



With a full featured J-1939 interface the M150L15 series panels provide a complete interface for virtually any SAE J-1939 data. With standard features such as "TSC1 Throttle Control", "Fuel Level Input", "Engine Oil Pressure" and "Engine Shutdown", the M150L provides the most features in the price range. The gateway interface is available in a 4" or 5" configuration. The M150L15 configuration can be shipped with variety of gauge configurations including; oil pressure, engine temperature, voltage and fuel expansion gauges.

Using the traditional look of a round gauge and the latest microprocessor technology the M150L15 series products provide the user with a traditional "look and feel" for controlling the latest electronic engines. Incorporating the latest technology allows the M150L products to be fully scalable from a single gauge solution to a full feature multi-gauge applications.

Other Commercial and Military Grade instruments

Electronic & Mechanical Gauges



Fuel Level Sender

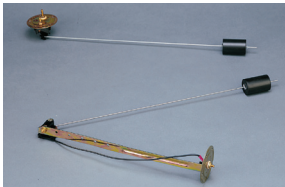

Pressure Senders

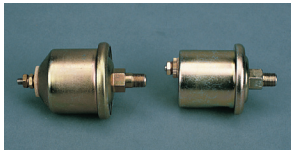

Pressure Switches

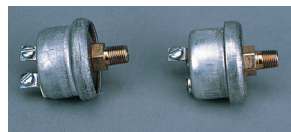

Temp. Senders



Temp. Sender/Switch



Tachometers

Tachometers are available in 2", 4" and 5" configuration with or without the hourmeter.



4 inch

2 inch

Combination Gauges



4 in 1

3 in 1

Other configurations available!

Snap-in Gauges



- Designed to SAE specifications for Dust, Vibration and Water intrusion.
- Provide a Heavy Duty instrument in a easy to install push-in case manufactured in the USA.
- No back clamp, washers, nuts or tools are required to install the gauge into your panel.

2-inch Multi-function Gauges



Available as Voltmeter, Pressure gauge, Temperature gauge, Fuel Level gauge with Digital hourmeter or Tach-Hourmeter function.

2-inch Stepper Motor Gauges



- Direct Replacement for Analog Gauges
- Stepper Motor Driven gauges for increased Accuracy and Gauge Life.
- Uses Analog inputs
- Can be configured for any Analog configuration.

Serving Industry Leading Companies

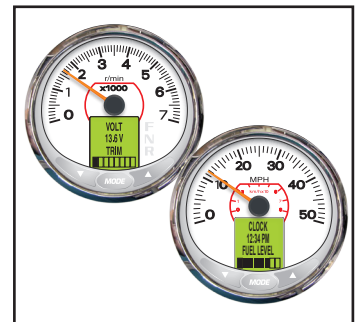
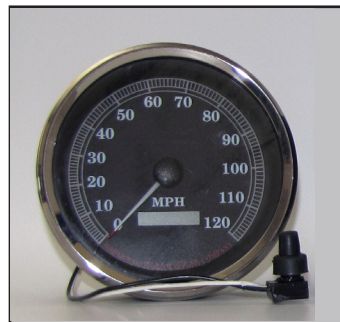

Faria Corporation

P. O. Box 983
Uncasville, CT 06382
860.848.9271
Fax: 860.848.2704

Beebe Instrument Company, Inc.

88 Village Street
Penacook, NH 03303
603.753.6362
Toll-free: 800.451.8255
Fax: 603.753.6201



Made in the USA