

ENGINEERED *Excellence*™

GPS™
SPEED

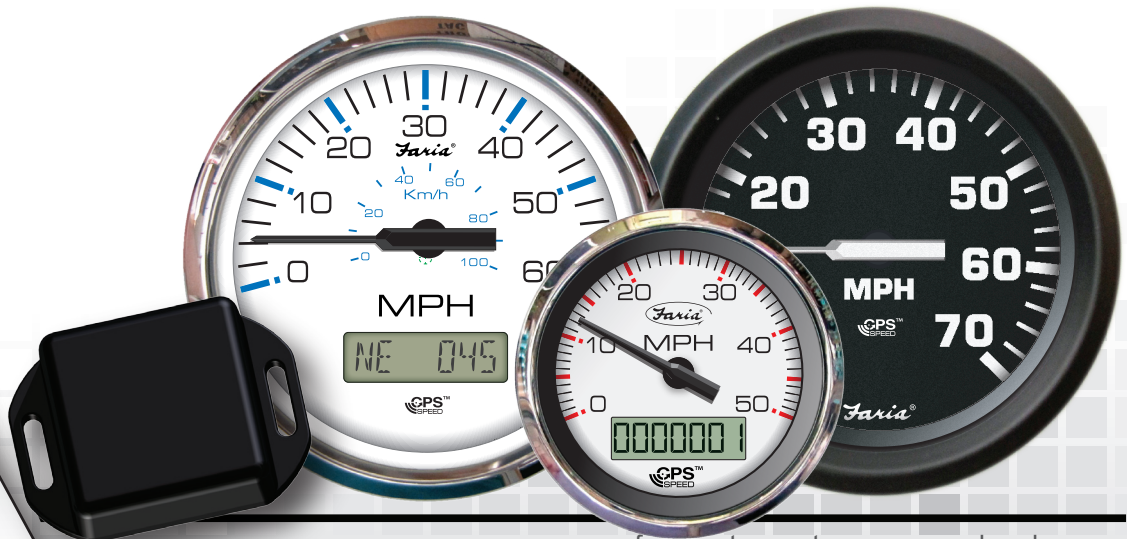

The GPS Speedometer is a drop in replacement for your current speedometer and can be made to match your existing instrument dash.

GPS information is gathered from an internal GPS antenna. No external antenna required. The Faria GPS Speedometer uses a highly accurate 48 channel GPS receiver. You can be sure that the Faria GPS Speedometer is giving you the most accurate GPS information available on the market today.

Speed data is shown by an analog pointer. This pointer is driven by a digital stepper motor for increased accuracy and minimized pointer bounce.

Why use GPS Speedometers?

Speedometers in the past have been limited by a mechanical movement. Moving parts wear out and fail. Pitot tubes clog or break, Paddle Wheels get tangled up. Mechanical linkages bind. Whatever the mechanical connection to the Speedometer in your dash it is a matter of when not if it will fail.

GPS Speedometers do not rely on mechanical devices to calculate speed. All you need is open sky and an antenna. The Faria GPS Speedometer removes the need for an external antenna. NO EXTERNAL ANTENNA required.

How does GPS work?

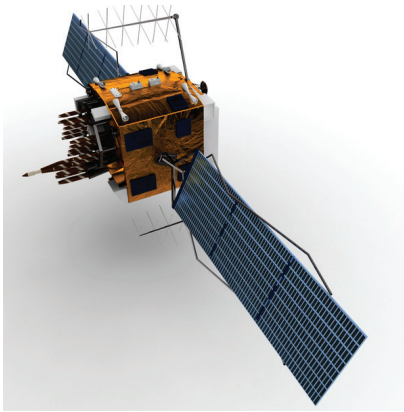

The Global Positioning System (GPS) is a network of about 30 satellites orbiting the Earth at an altitude of 20,000 km. The system was originally developed by the US government for military navigation but now anyone with a GPS device can receive the radio signals that the satellites broadcast.

Wherever you are on the planet, at least four GPS satellites are 'visible' at any time. Each one transmits information about its position and the current time at regular intervals. These signals, travelling at the speed of light, are intercepted by your GPS receiver, which calculates how far away each satellite is based on how long it took for the messages to arrive.

Once it has information on how far away at least three satellites are, your GPS receiver can pinpoint your location using a process called trilateration.

This is done several times a second. Every time you move the position is calculated and the distance you moved and the time it took you to get there is calculated and the difference is reported as speed.

Product Features

- **No external GPS antenna required**
- Available in multiple Speed ranges to 80 MPH, 130 KPH, 50 and 70 KNOTS
- Premium LED back-lit.
- Available with and without LCD displays showing Compass Rose heading and Actual heading (COG)
- Ultra fast Satellite acquisition time (TTFF) 1 second from Hot start
- Speed Accuracy of +/- 1 MPH
- Heading Accuracy of +/- 1 Degree
- Digital stepper motor driven pointers
- Perfect for slow moving vessels where pitot tubes just don't work
- Ideal replacement for speed sensing devices (pitot tube and paddle wheel) that can fail over time
- Deutsch connector cases
- Custom OEM styles and ranges available

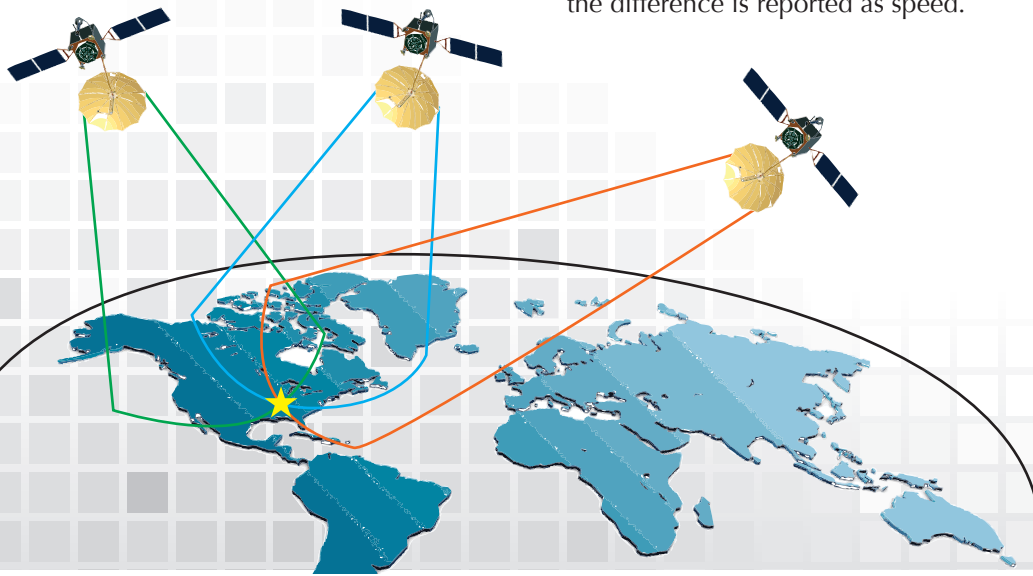

Trilateration

Trilateration is a calculation of position based on how far away you are from the source satellites.

GPS receivers measure the time a signal is sent from a satellite to the receiver and calculates the distance. When three, or more, satellite signals are received the overlapping distances are calculated and where the distances overlap there you are.



DISPLAY (Optional)

Choose between one of two functions for the optional LCD display. Course Over Ground or Odometer and Hourmeter.

Course Over Ground

The LCD display shows Heading and Compass and is back-lit for readability in inclement weather.

The LCD displays Compass Rose headings and actual course over ground heading. Heading is updated in 1° increments.

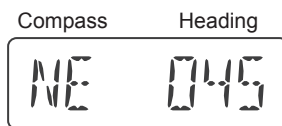

Odometer/Hourmeter

The display is a seven character LCD and can display up to 9,999,999 units in increments of .1 units. The LCD is back-lit with diffused LED light to provide maximum readability.

Displays Odometer or "Engine Running Only" Hourmeter hours.



ACCURACY

The Faria GPS Speedometer has a Speed accuracy of +/- 1 MPH while moving and a hot (normal stand-by) start up time (TTFF - time to first fix) of about 1 second or a TTFF from a cold (no power applied) start of up to 30 seconds.

Heading accuracy is +/- 1 Degree.

INTERFACE

The dial face is illuminated with a premium LED lighting system.

GRAPHICS

Faria can help design your own custom graphics. Many dial ranges and scales are available including lens type, bezel color, pointer color and back-lighting.

Available in multiple Speed ranges to 80 MPH, 130 KPH, 50 and 70 KNOTS

available in
MPH • KPH • KNOTS

ENCLOSURE

The enclosure is molded from Polycarbonate plastic with integrated Deutsch style connector shells (sockets) or studed case and is sealed against water intrusion in accordance with Ingress Protection (IP) rating IP67. Wires terminate to a sealed Deutsch weatherproof connector or ring terminals. This wire configuration allows the GPS Speedometer to work as a **Plug and Play** addition to your current dash.

Sizes for a standard 4 inch (85 mm) 5 (112 mm) and 2 inch (53 mm) instrument dash hole.

A Speedometer to fit your needs

Faria is offering the GPS Speedometer in a wide varieties of capabilities and functions. Because every need is different.

Deutsch connectorized harness

This premium style Speedometer is designed with the very latest technology. It is designed to fit directly into today's dash harnesses with easy Plug and Play connectors. Premium LED lighting and an optional diffused LCD display.

Available in 5-inch, 4-inch and 2-inch styles.

Studded harness

The Studded Speedometer offers an easy way to add GPS technologies to your dash. Designed to fit into existing dash harnesses all ready installed. The Studded Speedometer connects directly to the battery and ground without the addition of a costly connector. Edge lit dials are easy to read in foul weather. Available in all Faria Classic styles.

Available in 4-inch and 5-inch styles.

Stand-Alone GPS Antenna

The new GPS100 from Faria is small in size but packs a lot inside. The Faria GPS100 uses a highly accurate 48 channel GPS receiver.

Designed to connect directly into the NMEA0183 harness.

Use the new GPS100 antenna wherever you would use the current GPS antennas. Ultra fast Satellite acquisition times (TTFF), with Speed Accuracy of +/- 1 MPH. Works better than the traditional GPS antennas at just a fraction of the size.



Shown actual size

CASE SPECIFICATIONS

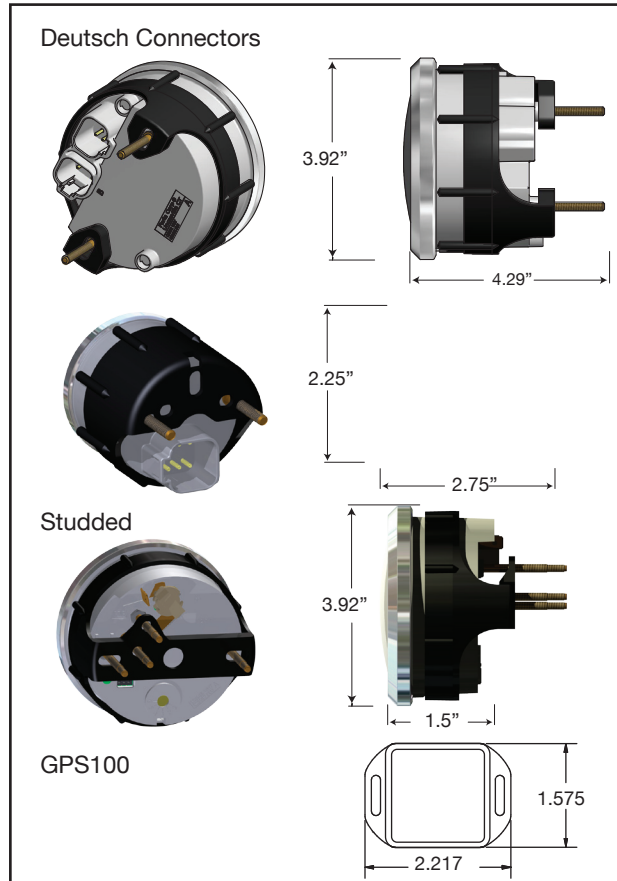

SPECIFICATIONS

GENERAL

Operating Voltage.....11.5 VDC to 16 VDC

Operating Temperature.....-20C to 70C

Storage Temperature.....-30C to 85C

Reverse Polarity Protection Yes

Display(optional) 7 Character LCD

Shock

50 +/- 2 G and a half sine duration of 11 +/- 2 ms. per MIL-STD-202, Method 213

Vibration

4 G peak, 10 to 200Hz

SAE J1455 Appendix A

Salt Spray

Front is Corrosion resistant per ASTM B117-73

Weather Resistance

Instrument has been tested to resist weather conditions in accordance with IP67 standards.

Connections

A: 4- pin connector

Pin 1	12 vDC (Ignition)
Pin 2	12 vDC (Keep-Awake)
Pin 3	Ground
Pin 4	Lighting
Pin 5	Not Used
Pin 6	Not Used

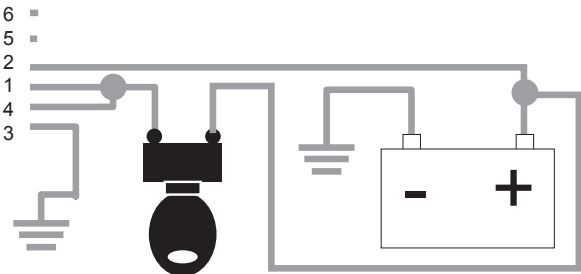
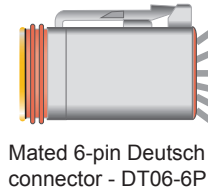

Blade Terminal (+)
Instrument Lighting Circuit

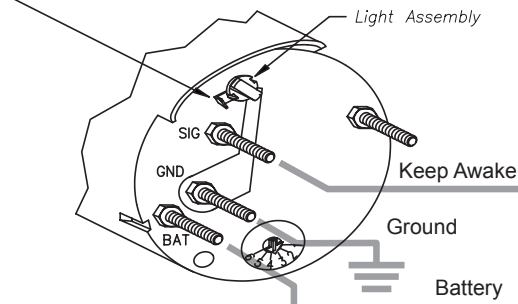

Faria Corporation
P. O. Box 983
Uncasville, CT 06382
860.848.9271
Fax: 860.848.2704

Beede Instruments
88 Village Street
Penacook, NH 03303
603.753.6362
Toll-free: 800.451.8255
Fax: 603.753.6201

