



Programmable Tachometer with Hourmeter

This tachometer can be programmed to function with 4, 6 and 8 cylinder gasoline engines or with diesel engines, and can be used with most ignition coils including Alternator and Mag pickup inputs.

The analog looking dial and pointer sweep is driven by a digital stepper motor providing greater accuracy and dependability than magnetically wound gauges. You get the advantages of digital instrumentation with the look and feel of the analog gauges.

General:

Mounting Hole: 3.375" (85 mm)
 Depth behind face plate: 3" (76 mm) min.

Cosmetic:

Dial: Black with White Graphics and Customer Logo
 Pointer: Fire Orange - Back Lit with Black Hub
 Lens: Glass
 Bezel: Painted Aluminum
 Display: 7 Character LCD
 Backlighting: Diffused LED light for display.
 Graphics turn red when lit.

Operational:

Mounting Bracket: Plastic
 Clamping Range: 0 - .8 in (0-20 mm)
 Torque: 5 to 7 inch pounds (.57 - 80 Nm.)
 Signal Input: Alternator / Magnetic Pick Up Input
 Min. Frequency: 1 PPR (33.33 Hz)
 Max. Frequency: 200 PPR (13,333 Hz)
 Wire Termination
 Packard Connectors

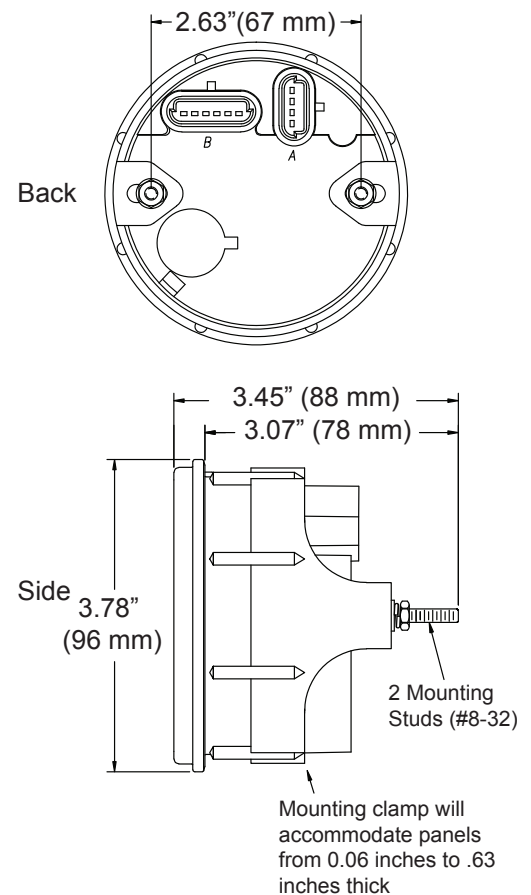

Specifications

Programmable Tachometer with Hourmeter

Calibration:	Tachometer: accurate to within $\pm 1\%$ of full scale Engine Hour Meter 0-999999.9 accurate to within $\pm 1\%$ of reading
Environmental:	
Required Specs	The electric Tachometer meets the requirements of SAE J1455 as specified below.
Temperature	
Operating	-20°C - +85°C
Storage	-40°C - +85°C
Voltage:	
Normal Operating	13 to 15 VDC at 25° \pm 3 ° C.
Extreme variations	11.5 to 16 VDC at 25° \pm 3° C.
Abnormal Voltage Conditions:	
Over Voltage	18VDC for 60 minutes
Reverse Polarity	The instrument can withstand reversed battery terminal polarity indefinitely without damage or permanent shift of calibration.
Shock	50 +/- 2 G and a half sine duration of 11 +/- 2 ms. per MIL-STD-202, Method 213
Vibration	4 G peak, 10 to 2000Hz SAE J1455 Appendix A
Salt Spray	Front is Corrosion resistant per ASTM B117-73
Water Leakage	Gauge is sealed from water entry from the front of gauge.
Weather Resistance	Gauge has been tested to resist weather conditions.



Proudly Made in Uncasville, CT USA

For more information:

Thomas G. Faria Corporation
P.O. Box 983
385 Norwich-New London Turnpike
Uncasville, CT 06382
t. 860.848.9271
f. 860.848.2704