



**BEEDE
INSTRUMENTS**
Since 1917

**World Class Engine
Monitoring and Analog
Instrumentation**



**Designed and
Manufactured
in the USA**

With some of the most sophisticated information and instrumentation systems in the industry, and a range of products that are rugged enough to survive on military Humvee and heavy construction equipment, or with innovative styling for your boat or RV, Thomas G. Faria Corporation has the right products to meet future global needs for rugged, reliable, and innovative instrumentation.



An ISO9001-2008 Registered Company

For more than 50 years Faria has been dedicated to the principle of supplying our customers with the highest quality product at the most competitive prices.

All Faria instruments are performance proven under the most demanding conditions. They are factory installed original equipment with major manufacturers worldwide. You can rely on Faria Instruments for world class quality, dependability and ease of installation.

Our years of manufacturing experience and knowledge of the industries we sell to have taught us to listen to the market place. Our in-house product design and development, component manufacture and instrument assembly allow us to respond quickly to your needs.

The company-wide use of Statistical Process Control (SPC), not only for ourselves but by our vendors as well, allow us to maintain a consistently high standard. In 1998, our efforts were recognized by the world as we became an ISO9001 registered company. We continually reaffirm our commitment to this standard and are now registered as a ISO9001:2008 company.

With the recent purchase of Beede Instruments of Penacook, NH, Faria has expanded our manufacturing capabilities to offer a broader product offering, unsurpassed value and design for all of our markets, including the US Military, industrial, recreational and majority of the world's leading boat manufacturers.

We support our products with a comprehensive Limited Warranty. Should you need them, our dedicated Customer Service Technical Experts are ready to provide installation, troubleshooting and warranty assistance.

Instruments for
Automotive
Commercial
Industrial
Performance
Recreational
Marine
Military



Rugged • Reliable • Innovative
Gauges

 Made in the USA

Contact Us



P.O. Box 983 • 385 Norwich-New London Turnpike
Uncasville, CT 06382 • p: 860.848.9271 • f: 860.848.2704



David M. Hickey
President and CEO



Jason Blackburn
Vice President
Sales and Marketing
jasonb@faria-instruments.com
ext. 1212

Commercial and Military Sales



Bill Desjardin
Commercial & Military
Sales Manager
bill.d@faria-instruments.com
ext. 1236

Customer Service & Warranty



Jason Clark
Customer Service Manager
faria@faria-instruments.com
ext. 1229

Marine Sales



Frank Ahlbin
Marine Sales Manager
franka@faria-instruments.com
ext. 1303

Customer Service & Warranty:
800-473-2742

Sales Support

Monique Holdridge
Administrative Assistant
moniqueh@faria-instruments.com
ext. 1221



Bob Chayrigues
Aftermarket & Export Sales
bobc@faria-instruments.com
ext. 1262

Order Processing

Miriam Wilson
Order Processing Coordinator
miriamw@faria-instruments.com
ext. 1267



John Alexopoulos
OEM Sales Representative
Marine Sales
johna@faria-instruments.com
ext. 1301

Sam Fortes

Aftermarket Order Processing Coordinator
sam@faria-instruments.com
ext. 1208

Marketing & Advertising

Thomas Wedegis
Marketing Coordinator
thomasw@faria-instruments.com
ext. 1285



88 Village St. • Penacook, NH 03303
p: 603.753.6362 • toll-free: 800.451.8255 • f: 603.753.6201

Sales

Diane Hamel
Sales Administrator/Purchasing Manager
dhamel@beede.com
ext. 216

Customer Service

Wanda Foote
Customer Service
wfoote@beede.com
ext. 201

Control Panels and Instruments for Electronically Governed Engines



Universal M150L20 Series Control Panel

The M150L Series Control Panels are a universal platform of products designed to control J1939 electronically governed engines. With a family of panel configurations ranging from panel mount to single gauge to multi-gauge and a NEMA 4X enclosure virtually any installation can be met. If a panel or enclosure is not required the M150L series offers a kit containing all necessary parts that can be mounted in a customer specific panel design.

With a full featured J1939 interface the M150L series panels provide a complete interface for virtually any SAE J1939 data. With standard features such as "TSC1 Throttle Control", "Fuel Level Input", "Engine Oil Pressure" and "Engine Shutdown", the M150L provides the most features in the price range.

Using the traditional look of a round gauge and the latest microprocessor technology the M150L series products provide the user with a traditional "look and feel" for controlling the latest electronic engines. Incorporating the latest technology allows the M150L products to be fully scalable from a single gauge solution to a full feature multi-gauge applications.



Universal M150L15 Series Control Panel

With a full featured J1939 interface the M150L15 series panels provide a complete interface for virtually any SAE J1939 data. With standard features such as "TSC1 Throttle Control", "Fuel Level Input", "Engine Oil Pressure" and "Engine Shutdown", the M150L provides the most features in the price range. The gateway interface is available in a 4" or 5" configuration. The M150L15 configuration can be shipped with variety of gauge configurations including; oil pressure, engine temperature, voltage and fuel expansion gauges.

Using the traditional look of a round gauge and the latest microprocessor technology the M150L15 series products provide the user with a traditional "look and feel" for controlling the latest electronic engines. Incorporating the latest technology allows the M150L products to be fully scalable from a single gauge solution to a full feature multi-gauge applications.

SAE J1939

STANDARD FEATURES

- Analog Input for Fuel Level
- Analog Input for Engine Oil Pressure
- User configurable engine speed limits
- Programmable throttle operation
- Engine Maintenance Interval
- SAE J1939 compatible throttle control
- SAE J1939 compatible Diagnostics
- RGB LED backlighting multi-color display lighting
- Multi Language Support
- Remote Engine Shutdown
- Audible and Visual Alarms

Universal M150L Series Control Instruments

The M150L Series Control Kits are designed to provide Plug N' Play solutions for installations with existing panel designs and are featured in our L15 and L20 Engine Control panels. These kits are designed to control J1939 electronically governed engines.

With a full featured J1939 interface the L00 series kits provide a complete interface for virtually any SAE J1939 data. With standard features such as "TSC1 Throttle Control", "Fuel Level Input", "Engine Oil Pressure" and "Engine Shutdown", the L00 series kits provide the most features in the price range.

With the traditional look of a round gauge using the latest microprocessor technology the M150L series products provide the user with a traditional "look and feel" for controlling the latest electronic engines. Incorporating the latest technology allows the M150L products to be fully scalable from a single gauge solution to a full feature multi-gauge applications.

SAE J1939

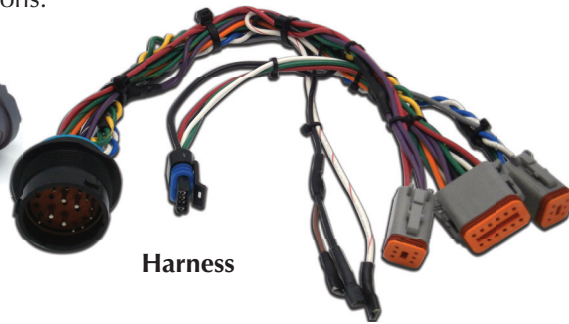

Oil Pressure



Water Temp



Voltmeter



Fuel Level

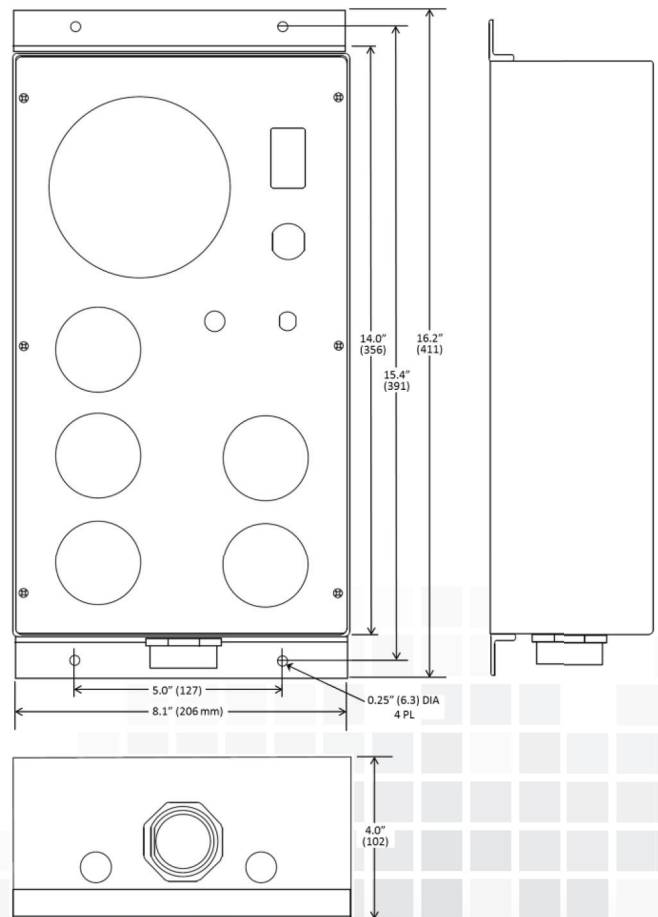
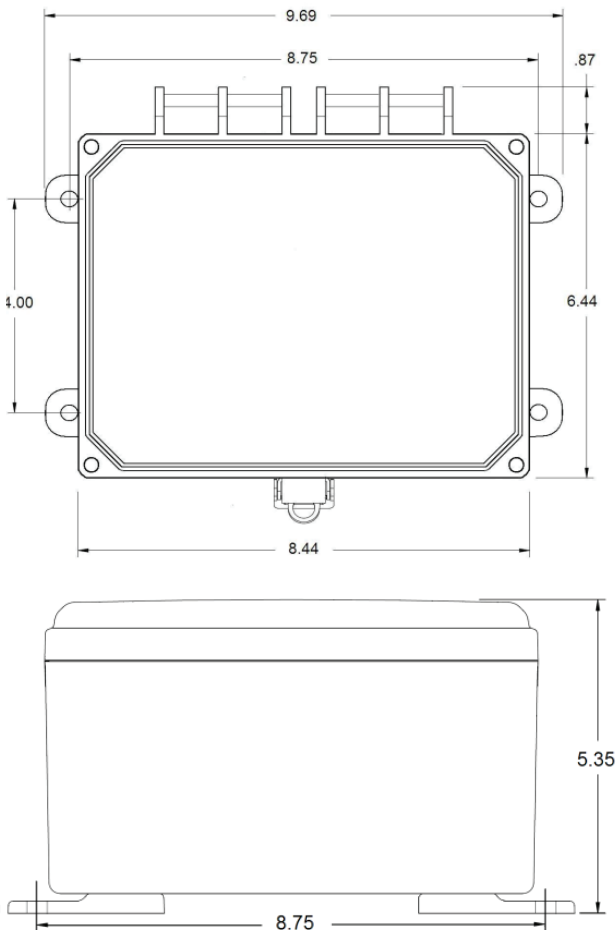

Stand-Alone J1939 Instruments

Faria offers a complete line of J1939 standard and Stand Alone monitoring solutions for your CAN Bus engines.



J1939 started as a communication and diagnostics tool in the car and heavy duty truck industry, J1939 is quickly becoming the norm in engine communications bus data for many more industries. Faria has worked with this protocol from its beginning. Today we provide many solutions for the different industries to have adopted J1939 including J-1939 Stand-Alone instruments.

Faria's J1939 Stand-Alone instruments are designed to plug directly on to the SAE J1939 bus. Each instrument uses CAN bus data to provide the operator the information in a familiar Analog display. Because each instrument talks directly to the J1939 CAN bus each instrument provides a redundant source of information. Faria offers the Stand-Alone instrument in a wide range of scale and styles. Many of the instruments can be used in Tier 4 applications. Best used where the operator only needs a few instruments to monitor the engine.

Features and Benefits

- J1939 CAN Bus Instruments
- Stand Alone technology - Each instrument receives information directly from the J1939 Bus
- Can be connected in standard J1939 harness configurations
- Available in a wide variety of styles.

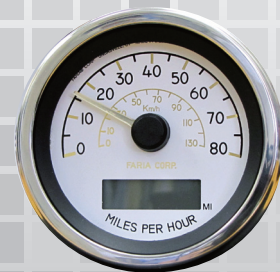

SAE J1939

J1939 Stand-Alone CAN Bus display



Instrument Shown
Actual Size



Configurable Two Line Display

Features and Benefits

- SAE J1939 CAN protocol support
- Compact packaging
- 32 X 128 dot matrix graphic LCD
- Displays active and stored faults (SAE J1939 DM1 & DM2)
- Single or Dual Line Display
- Three discrete LED indicators
- Alarm output capable of switching up to 150 mA
- Built in audible alarm (mutable)
- Built-in, sealed, tactile rubber keypad
- Bright, adjustable LED illumination
- Environmentally sealed connectors

Customizable Features

Bezel profile, material & finish
Dial face graphics & colors
LCD Illumination color

Product Description

The NexSysLink® CAN Bus display instrument reads and processes SAE J1939 compliant CAN messages.

The sunlight visible, transfective LCD displays operating parameters and is complemented by three discrete alert LED's.

An intuitive menu driven user interface accessed by three built-in tactile switches allows for easy display configuration. Stand-alone and Master Node (MNI) configurations available. MNI configuration drives NexSysLink® SNI & ASNI gauges.

SAE J1939 Parameter Set*

Parameter Name	SPN	Parameter Name	SPN
Accelerator Pedal Position	91	Fuel Rate	183
Alternator Voltage	167	Engine Fuel Temperature	174
Battery Current	114	Engine Hours	247
Battery Voltage	168	Engine Oil Level	98
Boost Pressure	102	Engine Oil Pressure	100
Coolant Level	111	Engine Oil Temperature	175
Coolant Pressure	109	Hydraulic Oil Level	2602
Coolant Temperature	110	Hydraulic Temperature	1638
DEF Level	1761	Intercooler Temperature	52
DEF Temperature	3031	Percent Load	92
Engine Speed (RPM)	190	Vehicle Miles	245/917
Exhaust Gas Temperature	173	PTO Speed	186
Fuel Economy (Average)	185	Engine Throttle Position	51
Fuel Level 1	96	Vehicle Speed	84
Fuel Level 2	38	Transmission Oil Level	124
Fuel Delivery Pressure	94	Transmission Oil Pressure	127
		Transmission Oil Temperature	177

*Only actively broadcast parameters appear on the LCD.

J1939 CAN Bus Panels, Clusters and Instruments



New designs, including the popular MG3000 digital LCD display, adds the features of our best selling digital instrument in a single panel cluster design. Customize your panel with warning lights and discrete gauge functions.

Features and Benefits

- J1939 CAN Bus Instruments
- Stand-Alone technology - Each instrument receives information directly from the J1939 Bus
- Available in a wide variety of styles
- Designed and manufactured to MIL-STD-1275, MIL-STD-465, MIL-STD-464, MIL-STD-810 and SAE J113-13 specifications
- Multiple Analog and Digital Inputs to reduce system costs
- Made in the USA
Uncasville, CT
Penacook, NH
- Wide variety of instruments including 3-1 and 4-1 multi-function gauges, 4-inch and 5-inch Speedometers and Tachometers and a complete suite of 2-inch discrete instruments i.e, Fuel Level, Temperature, Volts and Oil Level



SAE J1939

Multifunction gauges

Dash boards are getting more and more crowded as today's technology explodes on to our boats. Often there are so many beeps and buzzes it's hard to see just what's happening. Of course you can fill up your dash with lots of little two inch discreet gauges but that too is often just as confusing. That's why Faria developed our multi-function gauge.

Faria has combined the most useful discreet gauges into one gauge and then styled them to match any of our many Standard styles. But just like all the rest of our gauge you can make the look your own. Our award winning designers will design a style that is just right for you.

Combine up to 5 discreet function on one gauge. That's up to 10 functions in the space of your Speedometer and Tachometer. Suddenly the dash doesn't seem so crowded any more.

Let us be your solution for dash overload.

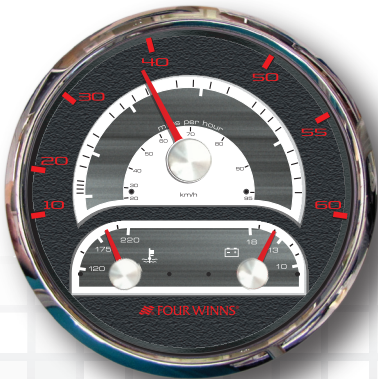
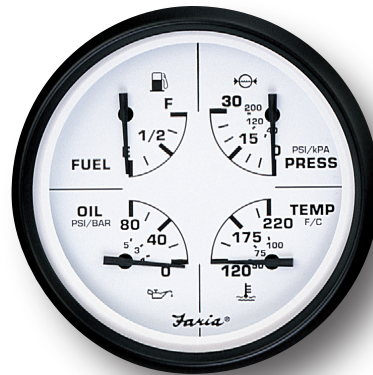
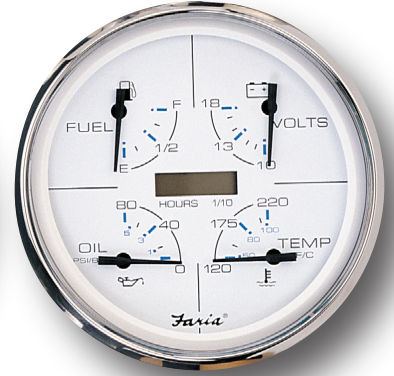

NexSysLink®

CAN Instruments Product Family

J-1939 Tell-Tale Indicator with 30 Icon Positions



Features and Benefits

- Environmentally sealed connectors
- Custom icon configurations available
- Up to ten discrete inputs switched either high or low
- SAE J-1939 CAN protocol support
- Connects seamlessly with NexSysLink MNI instruments
- Bright LED illuminated tell-tales
- Built in audible alarm and switched output

This CAN based product complements the NexSysLink® instrument system by providing thirty LED illuminated operator alert tell-tales along with an audible alarm to alert users to multiple fault conditions.

Product Description

The alert panel directly reads and processes SAE J-1939 compliant CAN messages, serial data from any NexSysLink Master Node Instrument and up to ten factory configurable discrete inputs switched either high or low to activate the tell-tales and/or audible alarm.

A discrete output capable of switching up to one amp and an audible output increase the utility of this product.

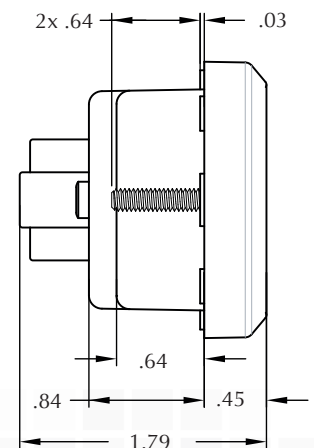

Front View

Snap-In Multifunction Gauges

Designed to SAE specifications for Dust, Vibration and Water intrusion. The Faria Snap-In instruments provide a Heavy Duty instrument in a easy to install push-in case manufactured in the USA.

This multifunction instrument provides many useful features in a small compact design. Available functions include; Inductive Tachometer, Hourmeter, Programmable Service Intervals and an analog discrete function (Ammeter, Voltmeter, Water Temp, Oil Temp, Oil Pressure, Fuel Level, Fuel Pressure)

No back clamp, washers, nuts or tools are required to install the gauge into your panel.

With its patented mounting design the Snap-In gauge is designed to install easily and reduce costs. Simply push through the mounting hole. The case springs out to hold your gauge in place.

A simple push of the fingers installs your gauge securely. No nuts, bolts or bruises required.

General:

Mounting Hole: 2.063" (53 mm)

Depth behind face plate: 3" (76 mm) min.

Lighting

- LED in multiple colors
- Perimeter lit dial
- Back lit dial
- Also available in an unlit dial version.

Dial Graphics

- Custom dials and masks available
- Add your own logo

Termination

- 8-pin Molex connector

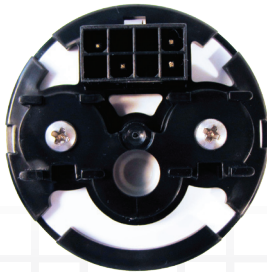

- Studs for ring connector (Ammeter only)

Lens

- Poly carbonate
- Glass
- Flat
- Domed
- Anti-fog coating available

Bezel

- Polished stainless steel
- Gold
- Variety of powder coated colors
- Variety of painted colors

Pointer

- Variety of painted colors



Patented Design

Features and Benefits

- Inductive Tachometer with Hourmeter
- Programmable Service Intervals with alarm
- US standard and metric values
- Poly carbonate cases for corrosion resistance and long life
- No hassle mounting - reduces installation time
- Available with or without embedded Digital Hourmeter
- 2 inch gauges - Ammeter, Voltmeter, Water Temp, Oil Temp, Oil Pressure, Fuel Level, Fuel Pressure and Hourmeter



MG3000

The digital gateway systems, available in the Speedometer or Tachometer, is a feature-rich, intuitive engine monitoring solution for the instrument market.

The digital instrumentation communicates directly with the J1939, NMEA2000 and SmartCraft protocols used by the engine ECU providing an important link between the operator and the engine ECU. With just a push of a button the operator can tell the status of the health of the engine including diagnostic messages, fault alerts, and parameter information.

With a full featured J1939 interface the MG3000 series instruments provide a complete interface for virtually any SAE J1939 data.

Connect to analog and digital signals to reduce installed costs significantly.

The MG3000 and other digital instruments from Faria are fully scalable from a single gauge solution to a full feature multi-gauge applications.

Display

The 128x64 color LCD display, available on the MG3000, provides an easy to read viewing area for system configuration and virtually any data reported by the ECU. The new daylight readable LCD is visible even in direct sunlight.

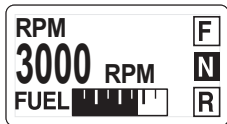

Yellow	Cyan	Goldenrod
Gr. Yellow	Blue	Tan
Green	Purple	White
Dk Sea Green	Pink	

The display is available with multiple RGB colors.

Interface

The MG3000 can be configured with or without the three front-mounted push button function selectors. These buttons control the user configurable software and provide access to variable menus and selections.

The MG3000 also allows for remote input device for control of the screens and data viewing.

Graphics

Faria can help design your own custom graphics. Many dial ranges and scales are available including lens type, bezel color, pointer color and back-lighting.

Enclosure

The enclosure is molded from Polycarbonate plastic with integrated Deutsch style connector shells (sockets) and is sealed against water intrusion in accordance with Ingress Protection (IP) rating IP67. Wires terminate to a sealed Deutsch weatherproof connector.

The case is available in three water tight configurations from fully waterproof to vented.

Depending on instrument type the case is available in 2, 4 and 5 inch standard hole sizes.

Accuracy

A digital stepper motor drives the pointers in Faria's digital instruments. The stepper motor increases the accuracy and reliability of the instrument while reducing jittery pointers and providing longer life with a lower power requirement.

Connectors

A water tight 12-pin and 6-pin connector is used for plug-in installation.

Maintenance Interval

User configurable maintenance interval. When programmed system provides warning message when maintenance interval has expired.



SAE J1939
SAE J1708



A user friendly digital engine monitoring solution.

Features and Benefits

- Tier 4 Compatible
- LCD data are available in 5 languages.
- Seasonal and Trip Data.
- Pop-Up screens for quick information display and warnings.
- Alarm codes with suggested actions.
- Data log for fault codes.
- A single Gateway instrument can monitor up to 5 tanks or other analog signals.
- Calibrate Fuel Level and Speed in gauge.
- Initialization mode to assist in gauge set-up.
- Superior Sunlight readable display.
- Units can be displayed in US standard or Metric
- Gear position indicators

Inputs

- CAN Bus (J1939, NMEA2000 and SmartCraft)
- Direct Pressure (30 PSI -200 kPa) and (145 PSI - 10000kPa)
- Analog Inputs
5 Analog inputs are available (Customer specific)

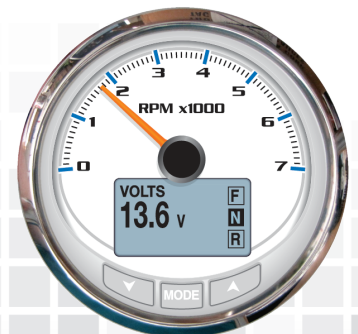

Customize to fit your needs. Available in 4 and 5 inch. With or without buttons.

Master Node Instrument (MNI) - NMEA2000



Product Features

- NMEA2000 certified CAN protocol support
- Large transfective dot matrix LCD
- Advanced stepper motor technology
- Supports up to three discrete analog sender
- Displays faults and warnings inputs including NMEA 0183 (GPS/Smart Transducer)
- Drives up to sixteen Slave Node Instruments (SNI)
- Expandable to ten analog inputs using
- Factory custom configurations and setups Analog Slave Node Instruments (ASNI)
- Bright LED illumination
- Bold, easy to read graphics
- Domed or flat glass lenses
- Environmentally sealed connectors

Product Description

This NexSysLink® instrument reads and processes NMEA 2000® compliant CAN messages and/or analog sender data. The instrument can transmit data to a maximum of 16 minor gauges via a three-wire daisy-chain harness.

The sunlight visible transfective LCD displays operating parameters along with fault and warning conditions.

An intuitive menu driven user interface allows for quick configuration of the instrument and display parameters.

Product Type and Range

Tachometer	Speedometer
0-4000 RPM	0- 30 MPH
0-6000 RPM	0- 50 MPH
0-8000 RPM	0- 85 MPH
	0-145 MPH

Custom ranges available

Gauge Size

3 Inch (Fits a 3.375 inch hole)

Customizable Features

Bezel profile, material and finish

Dial face graphics and colors

Company logo

Pointer cap and blade color

Trim ring color

Illumination color

Contact us for free information about our complete line of NexSysLink® products.

MG1000



The MG1000 is the stepping stone of digital instrumentation. This innovative digital gauge system requires no LCD's, no system initialization, no menu setups and no user manual interaction for use - ever! Just install and go boating!

The MG1000 gauge system displays engine ECU data and alarms. Installation is simplified by reducing wiring and setup time. Our instruments communicate with the engine ECU for the most accurate information and error codes.

This system is the lowest cost, most user-friendly digital product in the market for customers installing digital technology. Multiple analog inputs and warning lights reduce cost while still providing the customer with everything they need.

Upgrade to the MG3000 system for an even wider variety of options and features. The Faria product suite offers a multitude of accessory gauges available to connect to the MG1000 system including a 2" fuel flow gauge to show fuel economy. The combinations are limitless!!

Reduce cost with entry level digital engine monitoring.

Compatible with MG3000 systems.

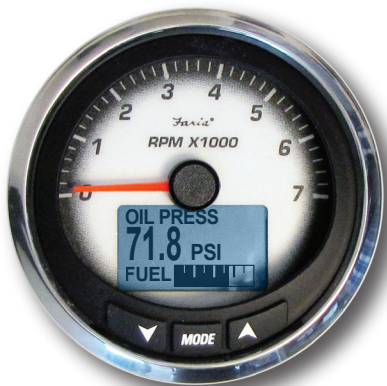

Features and Benefits

- Can be directly connected to NMEA2000 systems
- NMEA0183 input for GPS Speed
- A single Tachometer can monitor up to 4 fuel tanks
- Use to monitor up to 5 engines
- Add additional features, connect the MG3000 with the same harness
- Utilizes both analog and digital inputs to reduce system cost
 - Speed
 - Fuel
 - Trim
 - Water pressure
 - Temperatures
- Stepper motor gauges (for greater accuracy and durability)
- Deutsch and Packard marine connectors
- LED lighting is standard
- Custom cosmetic options upon request
- Multiple 5"/4"/2" discrete instruments are available

Specifically designed to work with the leading engine manufacturers.

The MG1000 displays the critical data and information that operators need in a simple, lower-cost, intuitive package.

Multiple Discrete Gauges Available

Slave Node Instrument (SNI)

Transmission
Temperature
with Warning
Indicator
Illuminated

Voltmeter

Dual Scale
Oil Pressure



Product Description

This NexSysLink® instrument receives and displays data transmitted by a Master Node Instrument (MNI)

The instrument provides a full 250° pointer sweep and a large engine fault and warning indicator.

Product Type and Range

Single Scale Instruments

- Air Pressure (Front) - 0-150 psi
- Air Pressure (Rear) - 0-150 psi
- Air Pressure (Primary) - 0-150 psi
- Air Pressure (Secondary) - 0-150 psi
- Ammeter - 125-0-125
- DEF Level - E-F
- Engine Coolant Temperature - 100-240°F
- Engine Oil Pressure - 0-80 psi
- Engine Oil Temperature - 100-320°F
- Fuel Level - E-F
- Transmission Oil Pressure - 0-400 psi
- Transmission Oil Temperature - 100-320°F
- Volts - 10-16
- Volts - 16-36
- Volts - 20-32

Dual Scale Instruments

- Air Pressure (Front) - 0-150 psi/0-1000 kpa
- Air Pressure (Rear) - 0-150 psi/0-1000 kpa
- Air Pressure (Primary) - 0-150 psi/0-1000 kpa
- Air Pressure (Secondary) - 0-150 psi/0-1000 kpa
- Engine Coolant Temperature - 100-240°F (38-115°C)
- Engine Oil Pressure - 0-80 psi/0-550 kpa
- Transmission Temperature - 100-320°F (38-160° C)

Marine Only Instruments

- Trim Level - Up/Down

Custom ranges available

Customizable Features

- Bezel profile, material and finish
- Dial face graphics and colors
- Pointer cap and blade color
- Domed or flat glass
- Illumination color
- Trim ring color
- Company logo

Gauge Size

2 Inch (Fits a 2.063 inch hole)



The Faria EntelNet™ service is a multi part system which combines the information received from the engine ECU (via CAN Bus), Analog (resistance, voltage, etc.) or Serial data (RS-232 for NMEA 0183, typical for GPS) used by the MG3000/MG1000 and an over the air communications system, i.e. Wi-Fi, data to provide remote control and monitoring of on-board systems.

Cloud based engine monitoring and systems control.

SAE J1939

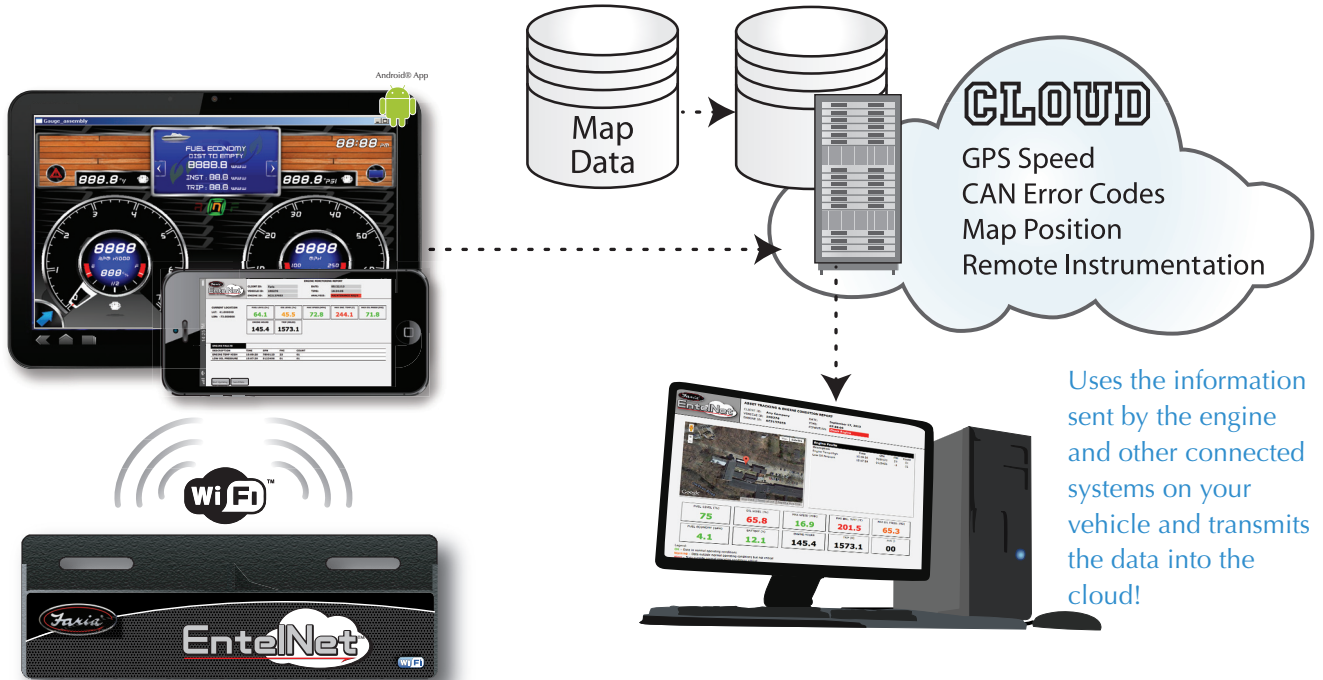

Uses the information sent by the engine and other connected systems on your vehicle and transmits the data into the cloud!

The MG3000 receives the CAN data and other information and parses it to the module for sending.

What Does That Mean?

With the EntelNet™ system you can use your smart device to monitor and control your engine data and critical vessel information right from the palm of your hand and view the Real-World data being sent by the ECU and send it to your Service Technician for diagnostics.

SAE J1939

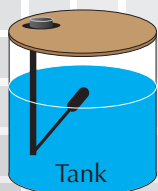

Level
Pressure
Temperature
Voltage
Environmental
and others



HTML Report Website

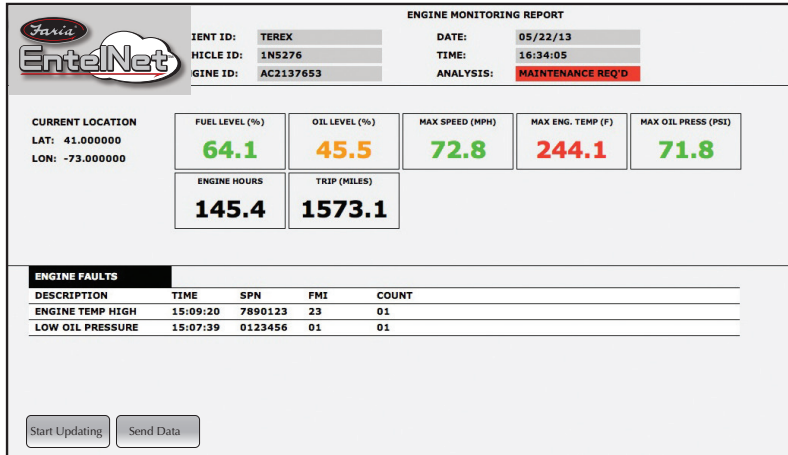

Real-World data sent from the MG3000, via the Wireless module is displayed.

The data, GPS speed, Map position, Instrument data and CAN error code information is displayed in an easy to read website and can be view by any internet capable device.



Get the technicians involved. Send the engine and other critical data anywhere in the world to be diagnosed. Helps reduce warranty costs and can help lessen repair time.

Send engine data into the Cloud!

GPS data and CAN information is sent in small byte sized packets to the smart devices. The end user can then send the data on to the cloud.

Servers can use this information to display GPS speed, Map position, Instrument data, Asset monitoring data and CAN error codes on an HTML website for remote viewing or to trigger alerts.



Faria is also developing a dedicated app made for the Android® market place.

Real-World data sent from the MG3000, via Wi-Fi, is displayed in a dedicated App for Android smart devices.

The data, GPS speed, Map position, Instrument data, Asset monitoring data and CAN error codes is displayed in a virtual instrument dash board right on the screen.

Multiple "pages" can be displayed including:

- Standard and Secondary instruments
- Ballast Tank monitoring and control
- Cruise Control
- Depth – Side scrolling contour
- Fuel Management
- Digital Switching and Lights
- Error Codes

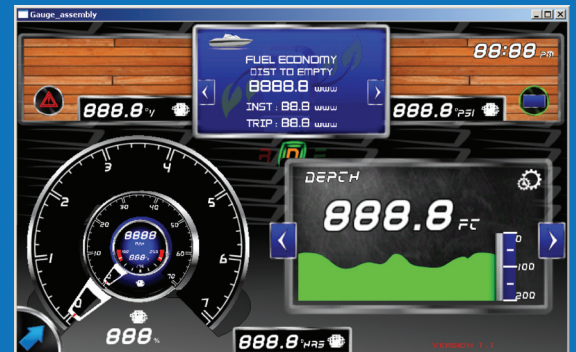

A complete solution for remote instrument monitoring!



Depth Sounders

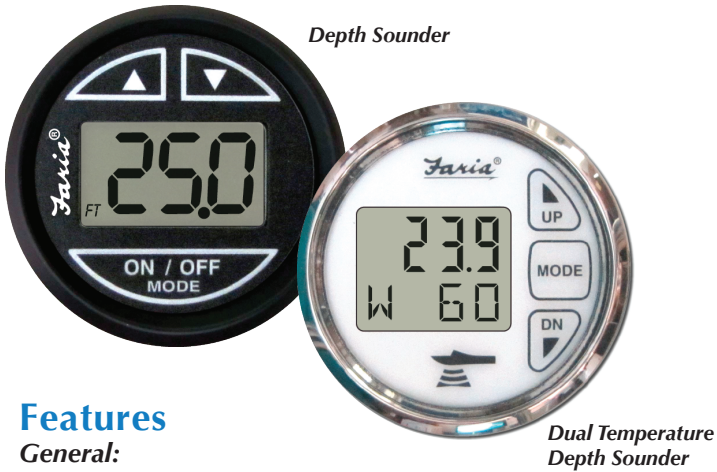

Features

General:

Mounting Hole: 2.063" (53 mm)
Depth behind face plate: 3" (76 mm) min.

- Depth Range: 3 to 199 feet (1 to 61 meters)
- Deep and Shallow water alarms
- Programmable Keel off-set
- Automatic Gain control
- Back lighting for maximum night vision;
 - Blue, White and Red LEDs available
- Metric or US standard units
- Easy to install!

Rated the best for accuracy with various bottom conditions.

Faria Engineers have incorporated the latest microprocessor technology and proprietary software designed to take advantage of today's high performance transducers. As a result this depth sounder outperforms all others on the market in its high speed capabilities and accuracy when faced with various bottom conditions.

Dual Temperature Depth Sounder displays Outside Air temperatures and Water temperatures from 32° F to 200 °F.

The Faria Depth Sounder is available in all Faria Styles, including Gold, Titanium, Polished Stainless Steel, Dress White, Euro, Kronos and many others.

Senders and Transducers

The Depth Sounder is available with either a Transom, In-Hull or a Through Hull transducer.

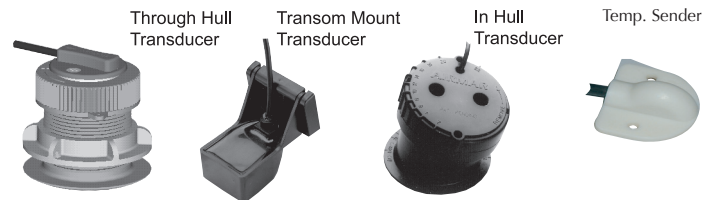

Electronic Programable Speedometer



Electronic speedometers operate by capturing pulses produced by a sensor. The pulses are then electronically converted to a speed-reading very much like a tachometer converts ignition pulses to RPM.

Features and Benefits

General:

Mounting Hole: 3.375" (85 mm)
Depth behind face plate: 3" (76 mm) min.

- Easy programming (for 1 or 2 axle ranges)
- Hourmeter function available
- Program service intervals
- Store highest speed
- Custom proprietary features available
- Easy calibration -
 - drive a measured mile
 - calibrate from inside cab
 - preset at factory
- Speedometer sensors available

Easy to install!

www.faria-instruments.com

GPS Speedometer



Features and Benefits

- Available in multiple Speed ranges up to 80 MPH, and 130 KPH
- Premium LED back-lit or edge-lit dials
- **No external GPS antenna required**
- Available LCD displays Compass Rose heading and Actual heading (COG)
- Ultra fast Satellite acquisition time (TTFF)
 - 1 second from Hot start
- Speed Accuracy of +/- 1 MPH
- Heading Accuracy of +/- 1 Degree
- Digital stepper motor driven pointers
- Ideal replacement for speed sensing devices (pitot tube and paddle wheel) that typically fail over time
- Perfect for slow moving vessels where pitot tubes typically don't work
- Deutsch connector cases

The GPS Speedometer is a drop in replacement for your current speedometer and can be made to match your existing instrument dash.

GPS information is gathered from an internal GPS antenna.

No external antenna required.

The Faria GPS Speedometer uses a highly accurate 48 channel GPS receiver. You can be sure that the Faria GPS Speedometer is giving you the most accurate GPS information available on the market today.

Course Over Ground (COG) and actual heading (compass heading over ground) are displayed on the digital LCD. Speed data is shown by an analog pointer. This pointer is driven by a digital stepper motor for increased accuracy and minimized pointer bounce during vessel operation.

Display

The character LCD displays Heading and Compass and is back-lit for readability in inclement weather.

The LCD displays Compass Rose headings and actual course over ground heading. Heading is updated in 1° increments.

Interface

The dial face is illuminated with a premium LED lighting system.

Accuracy

The Faria GPS Speedometer has a Speed accuracy of +/- 1 MPH while moving and hot (normal stand-by) start up time (TTFF - time to first fix) of about 1 second or a TTFF from a cold (no power applied) start of up to 30 seconds.

Heading accuracy is +/- 1 Degree.

Enclosure

The enclosure is molded from Poly carbonate plastic with integrated Deutsch style connector shells (sockets) and is sealed against water intrusion in accordance with Ingress Protection (IP) rating IP67. Wires terminate to a sealed Deutsch weatherproof connector. This wire configuration allows the GPS Speedometer to work as a Plug and Play addition to your current dash.

Mounting Hole: 3.375" (85 mm)

Depth behind face plate: 3" (76 mm) min.



Programmable Tachometer with Hourmeter

This tachometer can be programmed to function with 1, 2, 4, 6 and 8 cylinder gasoline engines and with most diesel engines, and can be used with most ignition coils including Alternator and Mag pickup inputs.

It is available in a wide range of scales or you can customize to fit your needs.

A versatile design from a leader in the engine monitoring industry, Faria products are designed to give you years of service and worry free performance.

General:

Mounting Hole: 3.375" (85 mm)
Depth behind face plate: 3" (76 mm) min.

Cosmetic:

Dial: Available in all Faria standard styles
Ranges: 0-4000 RPM, 0-6000 RPM, 0-7000 RPM, or customize to fit your needs.
Pointer: Back Lit with Hub or Molded Contour styles available.
Lens: Glass
Bezel: Painted Aluminum, Stainless Steel or SAE
Display: 7 Character LCD
Backlighting: Diffused LED light for display. Back-lit or Edge lit dials available
Customize options: Available



Operational:

Mounting Bracket: Plastic
Clamping Range: 0 - .8 in (0-20 mm)
Torque: 5 to 7 inch pounds (.57 - 80 Nm.)
Signal Input: Alternator / Magnetic Pick Up Input
Min. Frequency: 1 PPR (33.33 Hz)
Max. Frequency: 200 PPR (13,333 Hz)
Wire connections: Studded (Ring type) or with Packard connectors

2-Inch Variable Frequency Alternator Tachometer

This 2-inch Tachometer connects to the Alternator signal. The tachometer has four range selections for rough calibration and an adjustment potentiometer for fine adjustment.

The use of DIP switches on the back of this tachometer allows a rough calibration selection for the desired frequency.

The 2-inch Variable Frequency Alternator Tachometer can be used in 24 VDC systems with the use of an adaptor that connects between the 24 VDC ignition system and the tachometer.

General:

Mounting Hole: 2.063" (53 mm)
Depth behind face plate: 3" (76 mm) min.



Operational:

Signal Input: Alternator and Magnetic Pick Up Input
Min. Frequency: 400 Hz
Max. Frequency: 1600 Hz
Wire Termination: Blade Terminals
Backlighting: Perimeter Lit Dial with LEDs
Lights turn on when power is applied.

Tachometers

Universal Gas and Diesel

Available in 4 and 5 inch sizes with multiple ranges;
6000 RPM for Inboard and I/O engines
7000 RPM for all out board engines
3000 - 5000 RPM for diesel engines

These tachometers are available for all ignition systems, alternators and diesel engines. Available with or without a digital hourmeter which records upto 999999.9 hours.

SystemCheck Tachometer

7000 RPM universal tachometer with warning indicators for the Bombardier/Evinrude/Johnson SystemCheck engines.

Warning lights for No Oil, Engine Overheat, Check Engine and Low Oil.

Available in all Faria styles.

Suzuki Monitor Tachometer

7000 RPM universal tachometer with warning indicators for the Suzuki engine monitor system.

Warning lights for Check Engine, Temperature, Oil Level and Rev Limit.

Available in all Faria styles.

OBD Tachometer

Tachometer with warning indicators for the OBD (On-board diagnostics) monitor system.

Warning light indicates an OBD alert from the engine ECU.

Available in all Faria styles.

Programmable Tachometer with Hourmeter

This tachometer can be programmed to function with 1, 2, 3, 4, 6 and 8 cylinder gasoline engines or with diesel engines, and can be used with most ignition coils including Alternator and Mag pickup inputs.

The analog looking dial and pointer sweep is driven by a digital stepper motor providing greater accuracy and dependability than magnetically wound gauges. You get the advantages of digital instrumentation with the look and feel of the analog gauges.

2-inch Tachometer

Available in ranges from 1500 RPM to 4000 RPM. This 2-inch Tachometer connects to the Alternator signal. The tachometer has four range selections for rough calibration and an adjustment potentiometer for fine adjustment.



Custom Styles and Elegant Designs

ENGINEERED *Elegance*™

Faria can customize any gauge to fit your needs.

With 1000's of possible combinations and custom dial prints the possibilities are endless.

**Change the color of the bezel,
Add your logo,
Change the pointer...**



Watch Bezel styles



Jewel Tone Dials



Contour Gauges

Back-Lighted Dials with Bold Graphics on the Mask.

Multi-level formed graphics give you the feeling you could reach right into your dash. Back-lit pointers and Stainless bezels offer a look of elegance. Add a little distinction to your dash with the new Faria Contour Gauges.

These gauges can be customized and individualized to fit your graphics and color requirements.



Made in the USA

Classic Styling



Chesapeake Black SS

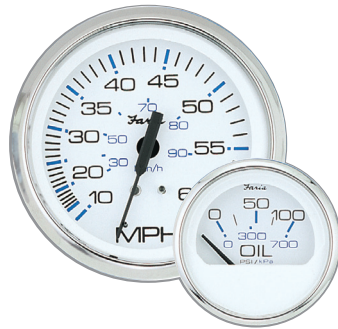

Chesapeake White SS



Coral



Dress White



Euro



Euro White

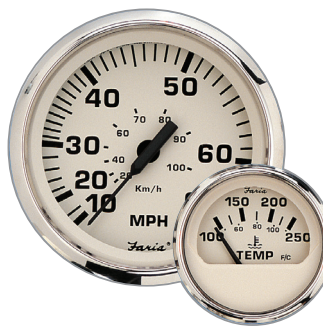

Euro Biege SS



Kronos



Platinum



Professional Red



Spun Silver

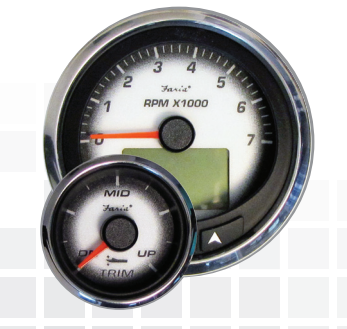

Digital Black Fade



Digital Gray Fade



Industrial Black,
Orange Pointer, Silver Bezel



Industrial Black,
White Pointer, Black Bezel

Faria Corporation
P. O. Box 983
Uncasville, CT 06382
860.848.9271
Fax: 860.848.2704

Beede Instrument
88 Village Street
Penacook, NH 03303
603.753.6362
Toll-free: 800.451.8255
Fax: 603.753.6201



Made in the USA