



Auto Start/Stop Engine Control Panel

for Electronically Governed Engines

DESCRIPTION

The M150 Series Control Panels are a universal platform of products designed to control electronically governed engines. With a full featured J1939 interface the M150 provide a complete interface for virtually any SAE J1939 data. With standard features such as “Auto Start”, “Universal Auxiliary Inputs”, analog inputs for both “oil pressure” and “fuel level” and an output for an audible alarm, the M150 provides the most features in the price range.

DISPLAY

The 4.25 inch (diagonal) LCD display provides a large viewing area for virtually any data reported by the ECU. The M150 displays diagnostic messages from the ECU per SAE J1939. Engine specific diagnostics messages are available for specified engines. (See part number section for list of specific engine types.)



ALARMS

The M150 displays diagnostic messages from the ECU per J1939 format. An active alarm display and an ECU generated historical alarm data display provide the user with easy access to system operation.

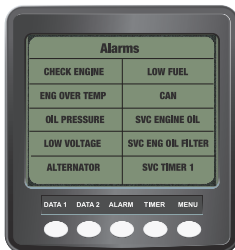

THROTTLE CONTROL

A single momentary rocker switch adjusts the engine speed via CAN Bus communications to the engine. The throttle functionality is user selectable allowing the rocker switch to provide a smooth ramp function or a fixed rpm 2-State setting. Universal auxiliary inputs allow the user to define remote throttle control values.

AUTOMATIC START / STOP

The M150 provides Automatic Start / Stop control utilizing a switch input for remote control of engine start / stop. The auto start / stop feature along with three remote speed inputs give the M150 a wide range of configurability to meet most any customer need.

PANEL

The M150 standard panel terminates to a sealed Deutsch weatherproof connect. For weatherproof conditions the M150 can be provided in a NEMA 4X housing.

STANDARD FEATURES

- Auto Start
- Analog Input for Fuel Level
- Analog Input for Engine Oil Pressure
- User configurable engine speed limits
- Remote engine speed selection
- Programmable throttle operation
- SAE J1939 compatible throttle control
- SAE J1939 compatible Diagnostics
- Audible and Visual Alarms
- External 3A Ignition Power

INPUTS

- J1939 Engine Data
- Oil Pressure
- Fuel Level
- Remote Speed Selection
- Remote Start Protect
- Remote Engine Stop

REMOTE SPEED CONTROL

The M150 Series Control Panel provides three user configurable engine speed settings. These speed settings can be set to any engine rpm within the min and max rpm range of the engine. An engine speed setting can be assigned to one of three available digital inputs allowing the M150 system to be configured for most field applications. The digital inputs provide complete flexibility for the user by allowing the input to be activated with a contact closure to ground or connection to Vbattery.



REMOTE ENGINE STOP

Remote Engine Stop is a user configurable input to remotely stop the engine. An engine stop setting can be assigned to one of three available digital inputs allowing the M150 system to be configured for most field applications. When the assigned digital input is activated the M150 system will shut the engine down. The digital inputs provide complete flexibility for the user by allowing the input to be activated with a contact closure to ground or connection to Vbattery. A typical use for the remote engine stop feature is a safety application requiring an emergency stop mechanism; such as "Man Off Seat".

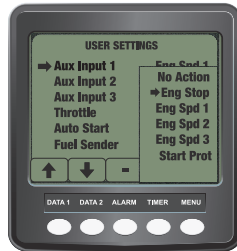

REMOTE ENGINE START PROTECT

Remote Engine Start Protect is a user configurable input to remotely prevent unwanted engine starts. An engine start protect setting can be assigned to one of three available digital inputs allowing the M150 system to be configured for most field applications. When the assigned digital input is active the M150 allows the engine to start. Should the input be inactive the engine will not start and the M150 will provide a popup display alerting the operator. Once the engine has started this input has no affect on the engine operation. A typical use of the remote engine start protect feature is a safety application requiring a device be disengaged prior to engine start.



FUEL LEVEL

User configurable analog input for fuel level sensors. US 240-33 and Euro 10-180 ohm senders can be selected.

AVAILABLE PARTS

M150GGP-50 CP; Control Panel, Generic - no enclosure
 M150GGE-50 CP; Control Panel, Generic - enclosure
 M150YRP-50 CP; Control Panel, Yanmar TNV - no enclosure
 M150YRE-50 CP; Control Panel, Yanmar TNV - enclosure
 M150JBP-50 CP; Control Panel, JCB - no enclosure
 M150JBE-50 CP; Control Panel, JCB - enclosure

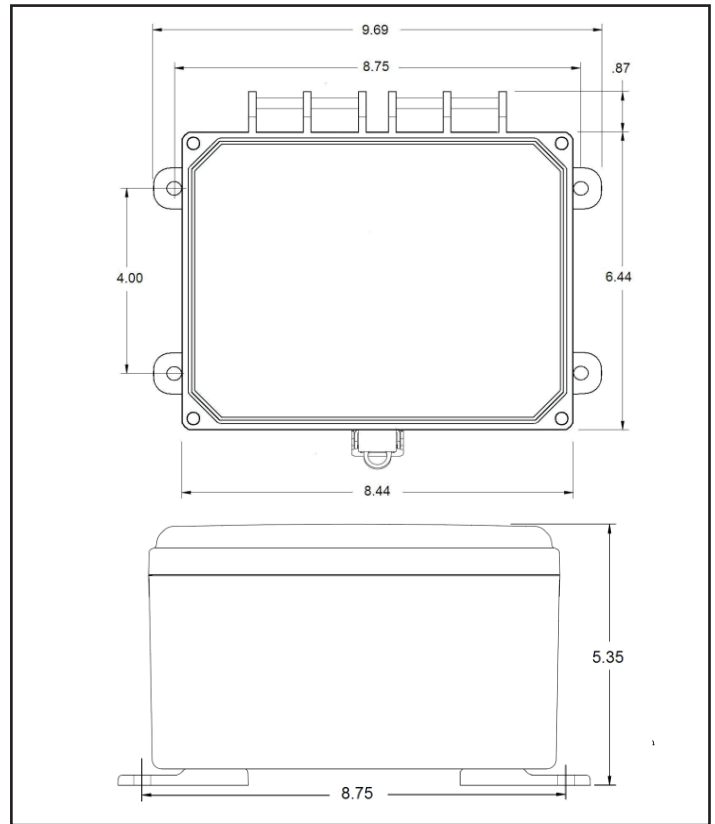

SPECIFICATIONS

GENERAL

Operating Voltage..... 6.0 VDC to 16 VDC
 Operating Temperature..... -25C to 75C
 Storage Temperature..... -40C to 80C
 Reverse Polarity Protection..... Yes
 Display..... Monochrome LCD 160 x 128
 Enclosure..... Polycarbonate NEMA 4x
 Approx Weight..... 3.5 lbs
 Approx Dimensions 8"H x 8.5"W x 5.5"D

INPUTS

Analog Inputs 2
 - 1 Channel Configurable for Fuel Level:
 - 240 to 33 ohms (US)
 - 10 to 180 ohms (EURO)
 - 1 Channel Configurable for Oil Pressure:
 - 10 to 180 ohms (0 – 80 PSI)

Digital Inputs 4
 - 1 Channel Auto Start/Stop active voltage signal >6.5VDC
 - 3 Channels Configurable for either
 - Start Protect
 - Engine Stop
 - Engine Speed 1 thru 3

Active signal: closure to ground or voltage > 6.5VDC

OUT PUTS

Ignition (3A) continuous (5A Peak) 1
 Solid State Relay (close to gnd) 1A..... 1

THROTTLE CONFIGURATION

Ramp - operate within engine range
 Two State – Set two operating speeds

For more information:

Thomas G. Faria Corporation
 P.O. Box 983
 385 Norwich-New London Turnpike
 Uncasville, CT 06382
 t. 860.848.9271
 f. 860.848.2704



www.faria-instruments.com